

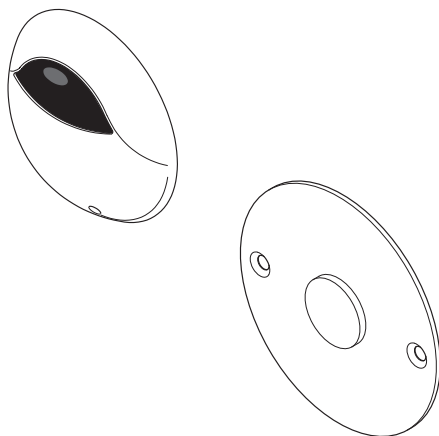

Rada Outlook Hand Control Sensors



T-logic™ Digital Intelligence



Pack contains one sensor only.

PRODUCT MANUAL

IMPORTANT

Installer: This Manual is the property of the customer and must be retained with the product for maintenance and operational purposes.

CONTENTS

DESCRIPTION	3
SAFETY : WARNINGS	3
PACK CONTENTS	4
SPECIFICATION	5
Standards and Approvals	5
INSTALLATION	5
General.....	5
Installation Schematic Diagram.....	5
Wire Length Schematic Diagram.....	6
RADA OUTLOOK SENSORS	7
General Notes on Installation Requirements.....	7
Hand Operated IR Sensor.....	8
Hand Operated Piezo Sensor	9
Creating A Sensor Extension Cable	10
SENSOR BOX CONNECTIONS	11
Connections Ports	11
Hand Sensors.....	12
COMMISSIONING	13
OPERATION	13
CLEANING	14
FAULT DIAGNOSIS	14
ACCESSORIES	15
SPARE PARTS	16
DISPOSAL & RECYCLING	16
GUARANTEE	16
CUSTOMER CARE	Back Cover

DESCRIPTION

A range of electronic Sensors designed to be fitted with the Rada Outlook Digital Mixer Valve and Sensor Box to produce a controlled washroom solution that complies with legislative and safety requirements whilst reducing the cost of building management. There are two types of sensor available:

1. IR Sensor: an Infrared non-touch sensor to control "on" or "on/off" functions.
2. Piezo Sensor: a Piezoelectric touch sensor to control "on" or "on/off" functions.

SAFETY : WARNINGS

The primary function of this product is to aid the delivery of water consistently at a desired temperature. This requires that:

1. It is installed, commissioned, operated and maintained in accordance with the recommendations given in this manual.
2. Periodic attention is given, as necessary, to maintain the product in good functional order.
3. If this equipment is used in a manner not specified by Kohler Mira Ltd, the protection provided by the equipment may become impaired.
4. The electrical installation **must** comply with BS 7671 (commonly referred to as the IEE Wiring Regulations) and all relevant building regulations, or any particular regulation or practice specified by the local electricity supply company.

PACK CONTENTS

Pack contains one sensor type only.

☐ 1 x IR Sensor

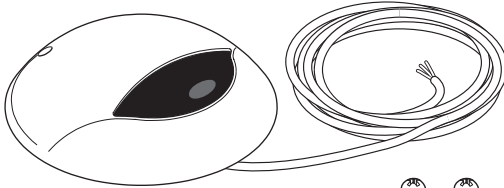

6m / 10m cable fitted

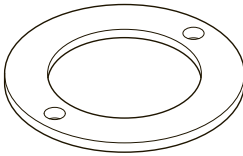

☐ 1 x Foam Seal

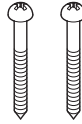

☐ 2 x Fixing Screws

☐ 1 x Hexagon Wrench

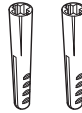

☐ 2 x Wall Plugs

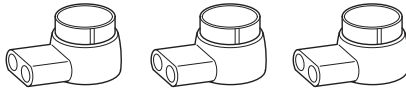

☐ 3 x 3M™ Cable Connectors

☐ 1 x Piezo Sensor

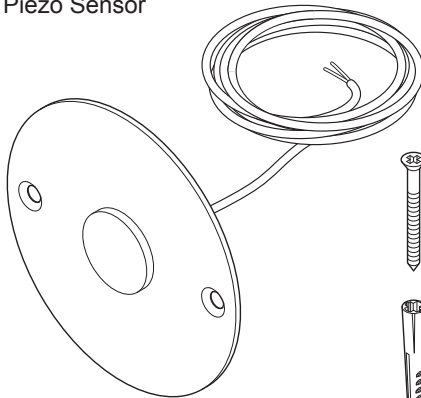

3m cable fitted

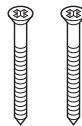

☐ 2 x Fixing Screws



☐ 2 x Wall Plugs

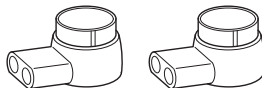

☐ 2 x 3M™ Cable Connectors

SPECIFICATION

Standards and Approvals

The **Rada Outlook Sensors** comply with all relevant directives for CE marking.

Power Input 5V DC supply provided by the Rada Outlook Sensor Box.

INSTALLATION

General

Installation must be carried out in accordance with these instructions, and must be conducted by designated, qualified and competent personnel.

The plumbing installation **must** comply with the requirements of the UK Water regulations/Bye-Laws (Scotland), or any particular regulations and practices specified by the local water company or water undertakers.

Warning! Do Not connect mains voltage directly to any of the Sensors.

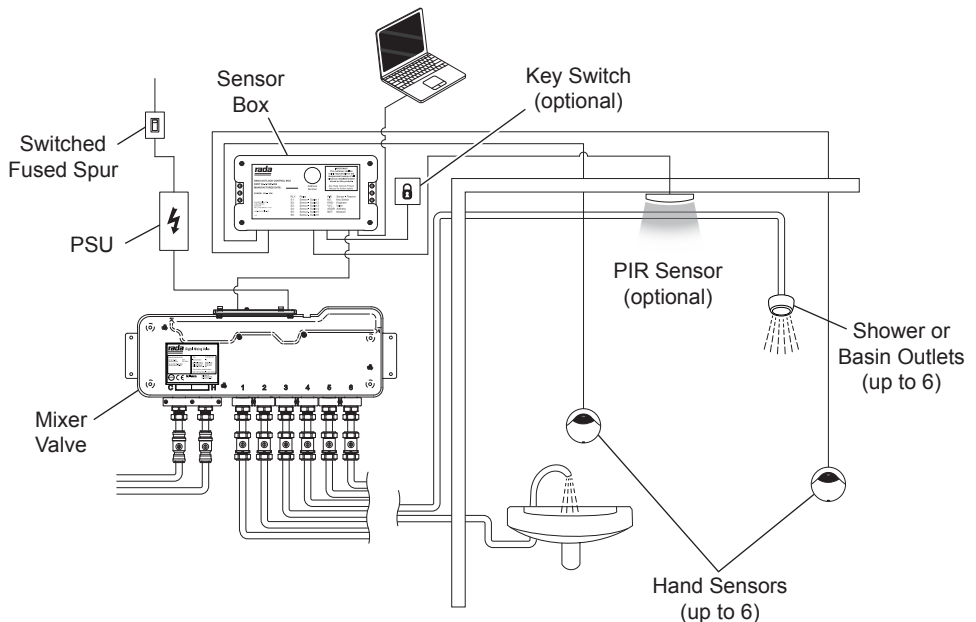

Installation Schematic Diagram

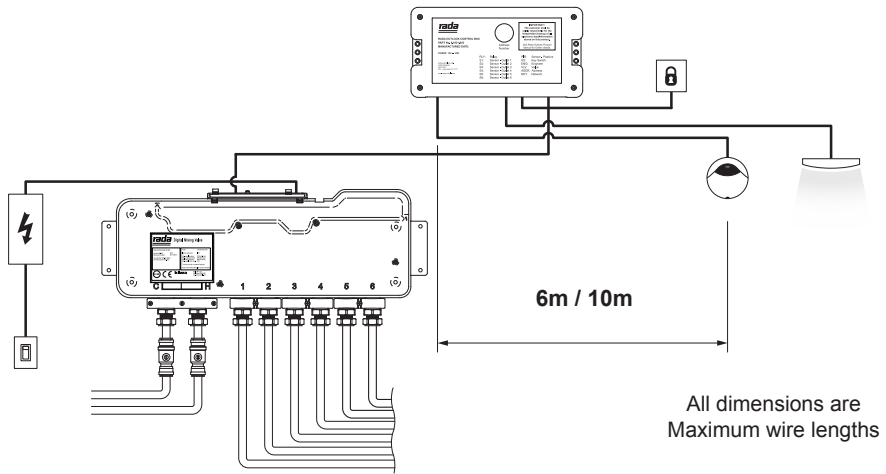

All dimensions are
Maximum wire lengths



Infrared sensor supplied with 6m / 10m signal cable fitted.



Piezo sensor supplied with 3m signal cable fitted.

Wire Length Schematic Diagram

RADA OUTLOOK SENSORS

General Notes on Installation Requirements

Sensors should be fitted outside of any direct water path, allowing access for adjustment and maintenance.

The sensors should be positioned a minimum of **0.5 m** away from any heat source to prevent false operation.

Make sure that the area is adequately ventilated. Steam or condensation may affect the sensitivity and operating life of the sensors.

Make sure the Sensors' "view" is always unobstructed.

Do not install any Sensor opposite a mirror or highly reflective surface.

Low voltage systems cables **must** be installed within conduit or trunking to provide sufficient physical protection and to allow removal or maintenance of system components.

Note! If a Sensor cable requires lengthening, use the 3M™ cable connectors supplied only. The connectors must be positioned within a dry area to prevent water ingress affecting the operation of the sensors. For further information see "**Rada Outlook Sensors - Creating a Sensor Extension Cable**".

**Isolate the power supply to the Sensor Box
BEFORE connecting the sensor wires.**

Dripping shower heads may cause sensors to trigger automatically, avoid installing the sensor directly in line with the shower head.

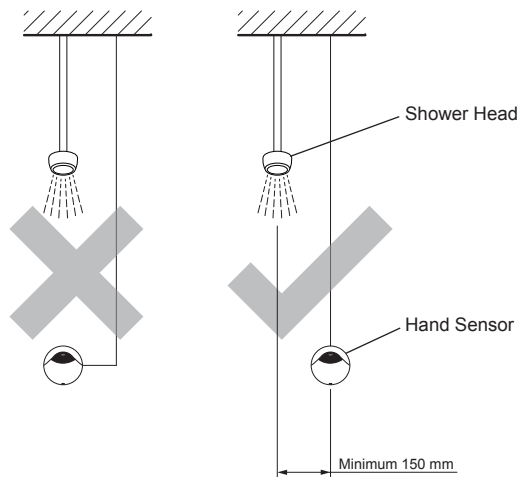

Hand Operated IR Sensor

1. Cut a hole and channel in the wall to run the cable from the Sensor to the Sensor Box. Ideally the Sensor should sit within a single tile to ensure a good seal. Make sure the channel is positioned correctly and large enough to prevent the cable having a sharp bend. Concealment of the cable in miniature trunking is recommended (**Fig 1**). If the Sensor is to be fitted to an existing pretiled area with no duct space in which to run cables, a groove can be cut between tiles using a disc cutter. Set the cable in the groove and cover with silicone sealant (**Fig 2**). For maintenance purposes within pretiled areas, it is recommended to bury some cable slack in a hole behind the sensor (**Fig 3**). If the cable requires lengthening, three "3M™" watertight connectors are supplied to create an extension cable (see **Creating a Sensor Extension Cable**). **Caution!** Do not drill into buried pipes or cables.

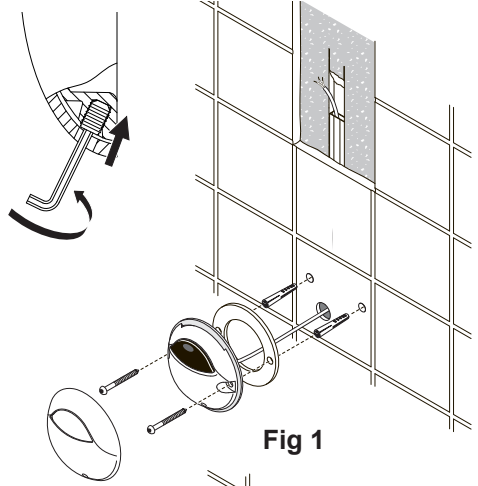

2. Screw in the cover screw to release and remove the Sensor cover.
3. Mark, drill and plug for the two fixing screws (supplied). Alternative fixings (not supplied) may be required for different wall structures. If the Sensor overlaps a groove between two or more tiles, fill any gaps with silicone sealant.
4. Secure the Sensor to the wall with two fixing screws.
5. Connect the Sensor cable to the Sensor Box. For systems with multiple sensors, make a list of their locations and corresponding connection numbers to the Sensor Box. This will aid set up of the control system.

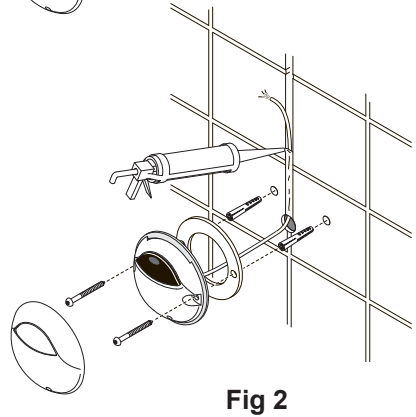

6. Refit the Sensor cover, making sure that it locates correctly over the top of the Sensor. Unscrew the cover screw to secure the Sensor cover.

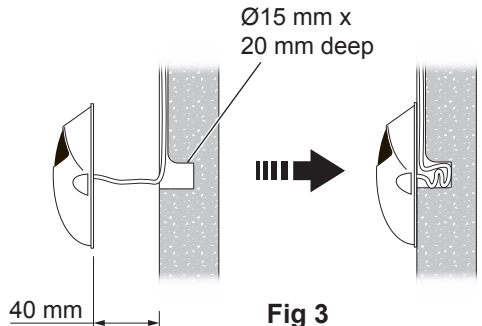

Hand Operated Piezo Sensor

1. Cut a hole and channel in the wall to run the cable from the Sensor to the Sensor Box. Ideally the sensor should sit within a single tile to ensure a good seal. Make sure the channel is positioned correctly and large enough to prevent the cable having a sharp bend. Concealment of the cable in miniature trunking is recommended (**Fig 4**). If the sensor is to be fitted to an existing pretiled area with no duct space in which to run cables, a groove can be cut between tiles using a disc cutter. Set the cable in the groove and cover with silicone sealant (**Fig 5**). For maintenance purposes within pretiled areas, it is recommended to bury some cable slack in a hole behind the sensor (**Fig 6**). If the cable requires lengthening, three “3M™” watertight connectors are supplied to create an extension cable (**see Creating a Sensor Extension Cable**). **Caution!** Do not drill into buried pipes or cables.
2. Mark, drill and plug for the two fixing screws (supplied). Alternative fixings (not supplied) may be required for different wall structures. If the Sensor overlaps a groove between two or more tiles, fill any gaps with silicone sealant.
3. Secure the Sensor to the wall with two fixing screws.
4. Connect the Sensor cable to the Sensor Box. For systems with multiple Sensors, make a list of their locations and corresponding connection numbers to the Sensor Box. This will aid set up of the control system.

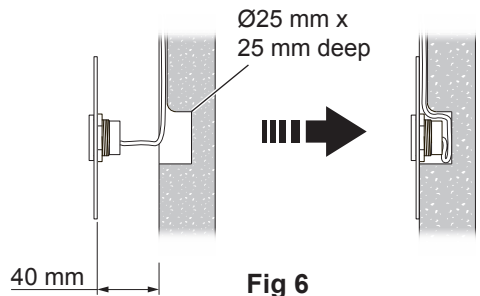
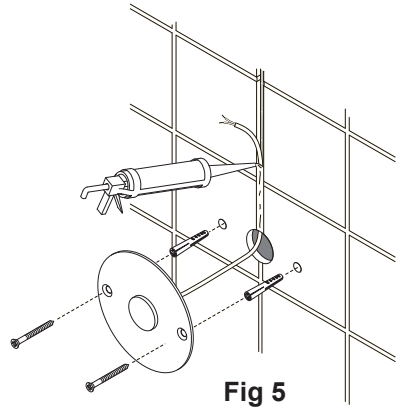
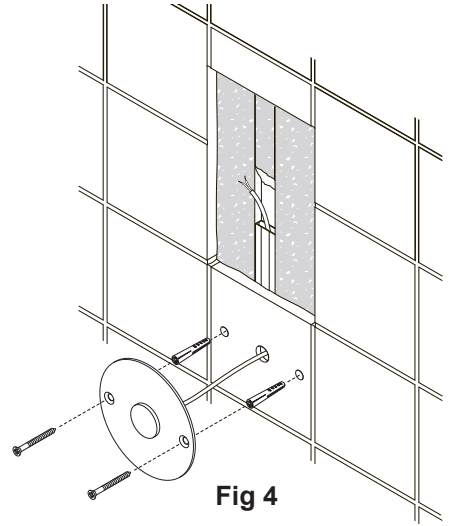

Extending a Sensor Cable

This product is compliant with all CE marking directives with sensor cables up to 6 meters in length. Should the cable be extended beyond this length, you must make sure the installation complies with all relevant directives and local regulations.

The Sensor cables can be extended by using the 3M™ connectors supplied. The extension must be to the same specification as the integral sensor cable (LAPP Unitronic LIYY).

Important!

- Do not use the 3M™ connectors to **shorten** the cable when replacing a sensor.
- Only use the 3M™ connectors supplied.
- After compressing, sealant is released. The use of any other type of connector may cause operation problems.
- Cable/Sheath ends must not be exposed to wet conditions and must terminate within a sealed enclosure or a fully sealed cable joint.
- Keep signal cables and power cables separate from each other to avoid electrical interference.

Isolate the power supply to the Sensor Box BEFORE connecting or disconnecting the sensor wires.

1. Insert the wire ends into the 3M™ connectors, make sure that they are fully pushed into the connectors so that the ends are under the jointing blades.

Note! Do not strip the wires, the jointing blades will make the connection through the outer sheath.

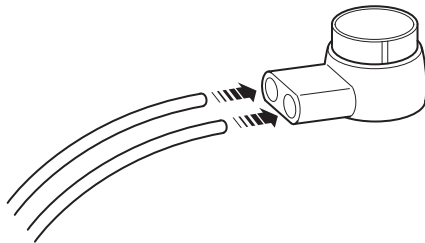

2. Using a pair of pliers, compress the connector to complete the connection.

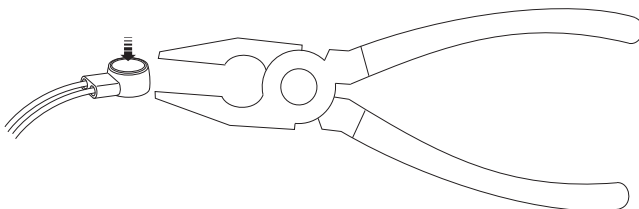

SENSOR BOX CONNECTIONS

Connection Ports

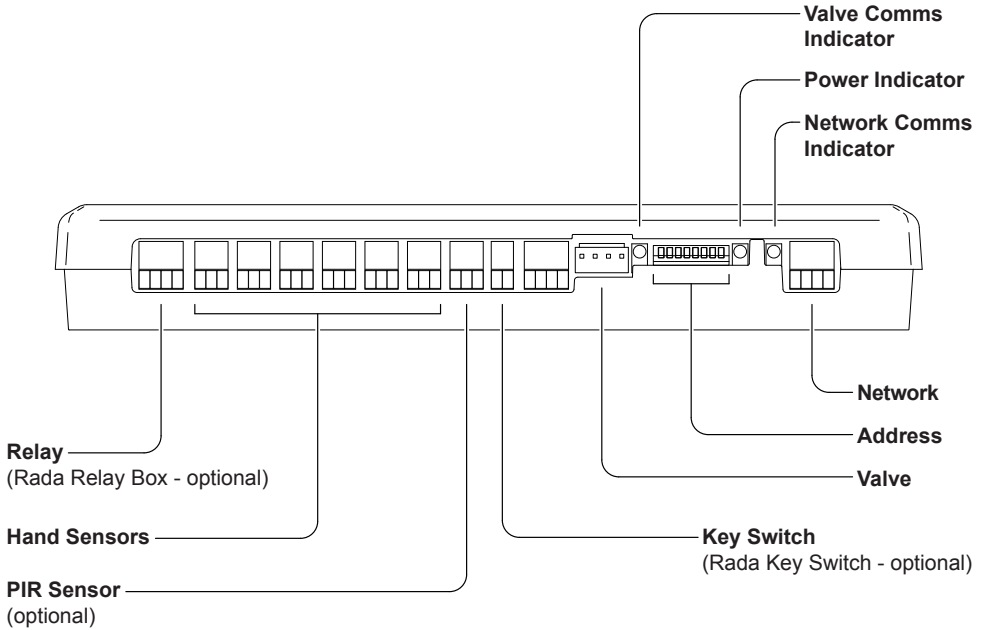

Caution! The Sensor Box has no protection against water or moisture and must be installed in a dry area. Installing the Sensor Box in an area where it may be exposed to water condensation or high humidity may result in a system control failure.

Hand Sensors

Connections are available for up to six hand sensors. **Only connect one sensor to one port.**

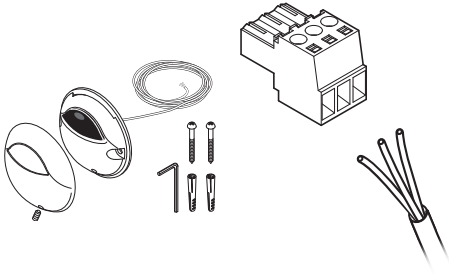

S1-S6

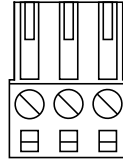

IR
0V (green)
I/P (white)
+5V (brown)

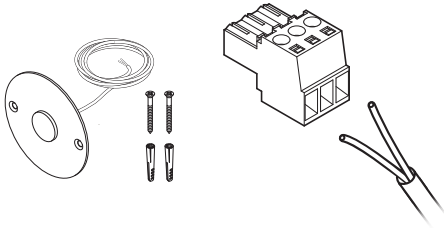

S1-S6

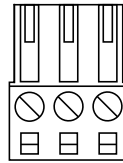

Piezo
0V
I/P

Rada Outlook Sensors - see “Accessories”

COMMISSIONING

Commissioning **must** be carried out in accordance with these instructions, and **must** be conducted by designated, qualified and competent personnel.

1. Restore the power supply.
2. Set each of the outlets using the Rada Outlook Control Software. Refer to “**Rada Outlook Configuration Tool Product Manual**” for full instructions.
3. After power is restored, the system will take 5-10 seconds to calibrate the Sensors before they can be operated. Activate each of the Sensors to start the Mixer Valve and flush out any air.
Hand Operated IR Sensor - Wave hand over the black lens to activate.
Hand Operated Piezo Sensor - Touch metal disc at the centre of the device.
4. Check the functions of the sensors are operating as expected.

OPERATION

The IR Sensor is designed to operate at a distance of up to 30 mm. There is no need for the user to touch the IR sensor.

The Piezo Sensor will activate when the metal disc in the centre is touched once.

Activate the Sensor to start the water flow.

The water flows from the outlet until either it is switched off manually by reactivating the Sensor, or the programmed flow time duration elapses.

The Rada Outlook Configuration Tool is used to alter/activate the following key features of the system:

Valve Setup

Outlet Setup

Duty Flush - Setup/Log

Disinfection - Setup/Activation/Log

Valve Calibration

(Refer to the “**Rada Outlook Configuration Tool Product Manual**” for further information on how to use these features.)

The Rada Outlook Control Software (supplied separately) is designed to run on a suitable PC/Laptop device with Microsoft Windows XP or Vista operating systems. (Refer to the “**Rada Outlook Configuration Tool Product Manual**”.)

CLEANING

The Rada Outlook Sensors may be disabled temporarily for cleaning and maintenance purposes. This is possible with the use of a Keyswitch or other similar device (not supplied) connected to the Sensor Box. (The Rada Keyswitch is available as an accessory suitable for this purpose, see “Accessories”).

Chrome Plated or plastic fittings should only be cleaned using a mild washing up detergent or soap solution and wiped dry with a soft cloth.

FAULT DIAGNOSIS

Maintenance **must** be conducted by designated, qualified and competent personnel.

Note! The following table is not an extensive list of faults, if you find a fault that is not listed below, please contact us for assistance.

Most faults can be rectified by checking the following:

Make sure the water supply has not been interrupted. All isolating valves should be fully open.

Symptom	Probable Cause	Remedy
1. Sensor not working. Sensor works once, then not at all.	A. Faulty connection. B. Faulty Sensor.	A. Check sensor wiring. Check wires are making good contact with the Sensor Box. If wires have been extended, check connectors between Sensor and Sensor Box. B. Replace sensor.
2. New or replacement Sensor not working within the first few seconds of being connected, Sensor works correctly afterwards.	A. Sensor is being calibrated. B. Sensor connected to a live (powered) Sensor Box.	A. Allow 5-10 seconds for the system to calibrate the Sensor before operation. B. Isolate power to the Sensor Box before connecting the Sensor.

ACCESSORIES



1621.112 Rada Outlook IR
Hand Sensor (6m)



1621.228 Rada Outlook IR
Hand Sensor (10m)

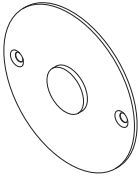

1621.085 Rada Outlook
Piezo Hand Sensor

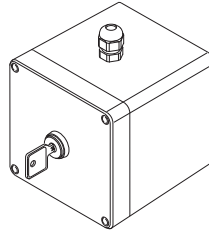

2.1495.080 Rada
Isolating Keyswitch

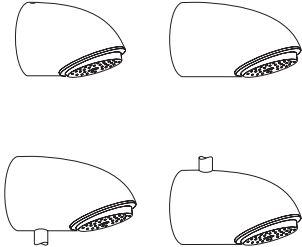

Outlet Fittings:

Rada has a comprehensive range of spouts and shower fittings, available separately.

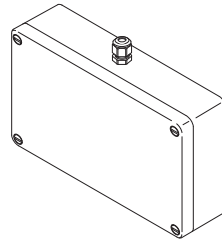

2.1495.044 Rada Relay Box

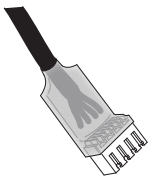

1621.116 Rada Outlook RS485 Socket

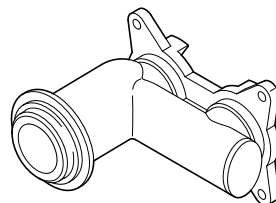

1621.115 Outlet By-Pass Adapter

SPARE PARTS

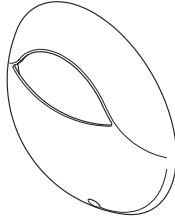

1.1621.095 IR Sensor Chrome Cover.

DISPOSAL & RECYCLING

End of Product Life

When the appliance has reached the end of its serviceable life, it should be disposed of in a safe manner and in accordance with the current local authority recycling or waste disposal policy.



GUARANTEE

Guarantee

Rada Outlook IR Sensor and Piezo Sensor

We guarantee these products against any defect in materials or workmanship for the period of **one year** from the date of purchase. For terms and conditions refer to the back cover of this guide.

NOTES

NOTES

NOTES

CUSTOMER SERVICE

Guarantee

Your product has the benefit of our manufacture's guarantee which starts from date of purchase. Within the guarantee period we will resolve defects in materials or workmanship, free of charge, by repairing or replacing parts or product as we may choose.

This guarantee is in addition to your statutory rights and is subject to the following conditions:

- The product must be installed and maintained in accordance with the instructions given in this user guide.
- Servicing must only be undertaken by us or our appointed representative. **Note!** If a service visit is required the product must be fully installed and connected to services.
- Repair under this guarantee does not extend the original expiry date. The guarantee on any replacement parts or product ends at the original expiry date.
- For shower fittings or consumable items we reserve the right to supply replacement parts only.

The guarantee does not cover:

- Call out charges for non product faults (such as damage or performance issues arising from incorrect installation, improper use, inappropriate cleaning, lack of maintenance, build up of limescale, frost damage, chemical attack, corrosion, system debris or blocked filters) or where no fault has been found with the product.
- Water or electrical supply, waste and isolation issues.
- Compensation for loss of use of the product or consequential or indirect loss of any kind.
- Damage or defects caused if the product is repaired or modified by persons not authorised by us or our appointed representative.
- Routine maintenance or replacement parts to comply with the requirements of the TMV2 or TMV3 healthcare schemes
- Accidental or wilful damage.
- Products purchased ex-showroom display.

What to do if something goes wrong

If your product does not work correctly refer to this manual for fault diagnosis and check that it is installed and commissioned in accordance with our instructions. If this does not resolve the issue, contact us for help and advice.



Technical Helpdesk Service

Contact our Customer Services Team for product advice, to purchase spare parts or accessories or to set up service visit. You can contact us via phone or e-mail - contact details below. Please provide your model name, power rating (if applicable) and date of purchase.



Rada Website (www.radacontrols.com)

From our website you can view our full product catalogue or download a brochure.



Spares and Accessories

We hold the largest stocks of genuine Rada spares and accessories.



Service/Repairs

No one knows our products better than our nationwide team of Service Technicians. We can carry out service or repair work to your product both during and after the guarantee period. You have the assurance of a fully trained Technician, genuine Rada spare parts and a 12 month guarantee on any chargeable work done.

Service Contracts

Regular servicing ensures your product continues to operate at the peak of performance. We offer annual or bi-annual servicing carried out by our fully trained technicians subject to site survey

To Contact Us - UK Customer Service & Specification Enquiries



0844 571 1777

Calls cost 7p per minute plus your phone company's access charge



Fax: 0844 472 3076



Email – Visit

rada_technical@mirashowers.com



By Post: Rada Controls, Cromwell Road, Cheltenham, Gloucestershire GL52 5EP

To Contact Us: Eire Only



01 531 9337



E-mail:

CustomerServiceEire@mirashowers.com

Rada is a registered trade mark of Kohler Mira Limited.

The company reserves the right to alter product specifications without notice.

