

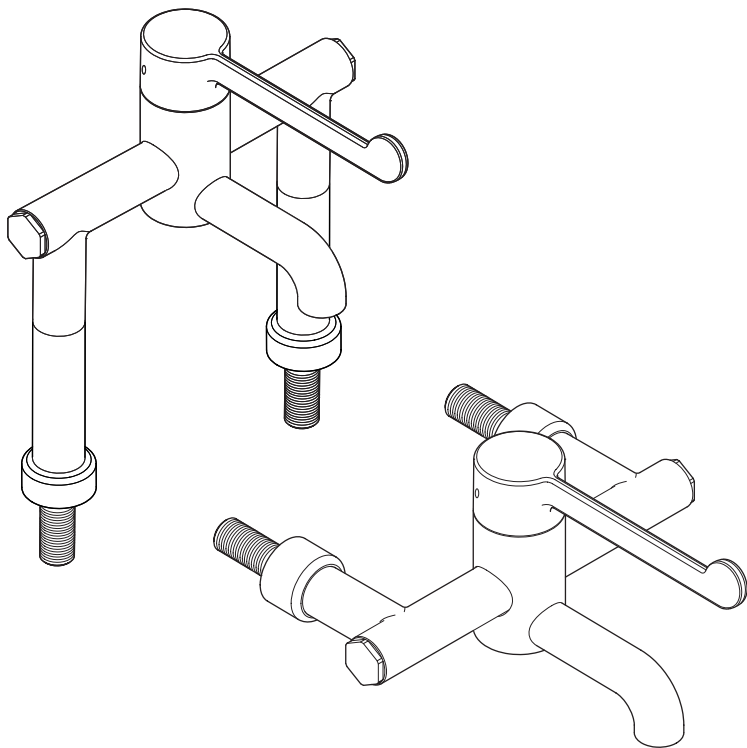

Safetherm



PRODUCT MANUAL

IMPORTANT

Installer: This manual is the property of the customer and must be retained with the product for maintenance and operational purposes.

CONTENTS

Introduction	3
Safety : Warnings	3
Pack Contents Checklist	5
Specifications	7
Pressures	7
Temperatures	7
Thermostatic Shut-down	8
Connections	8
Important Points	8
Dimensions.....	10
Installation	11
Panel Mounting	12
Basin Mounting.....	14
Operation	16
Commissioning	17
Maximum Temperature Setting	17
Fault Diagnosis	19
Maintenance	21
Planned Maintenance.....	21
Thermostatic Cartridge Renewal.....	22
Filter Renewal	23
Checkvalve Cartridge Renewal	24
Spare Parts	25
Notes	27
Customer Care	28

INTRODUCTION

Congratulations on purchasing a quality Rada product. To enjoy the full potential of your new product, please take time to read this guide thoroughly; having done so, keep it handy for future reference.

The Rada Safetherm is an exposed thermostatic control for connection to entry pipework from various directions. The thermostatic control incorporates a wax capsule temperature sensing unit. This provides an almost immediate response to changes in pressures or temperature of the incoming water supplies to maintain the selected temperature. An adjustable maximum temperature stop is provided which limits the temperature to the desired level. The Safetherm also includes checkvalves, filters and inlet flow regulators limiting the outlet flow to 8 L/Min.

The Rada Safetherm has been certified for use in UK Healthcare premises as a Type 3 valve under the BUILDCERT TMV3 scheme. For Healthcare* installations refer to the TMV3 Requirements Manual. This product also complies with the Water Supply (water fittings) Regulations 1999.

*Healthcare applications are hospitals, aged person facilities, residential care homes, etc. and any other application where the user is similarly at risk.

The approved designations for **Type 3 Valves** are as follows:

Model	Designation Code
Rada Safetherm	HP-WE, LP-WE

SAFETY : WARNINGS

Warning!

Products manufactured by us are safe provided they are installed, used and maintained in good working order in accordance with our instructions and recommendations.

Caution!

1. Read all of these instructions.
2. Retain this guide for later use.
For Type 3 installations, valves are only to be used for applications covered by their approved designations, refer to the TMV3 Requirements Manual.
3. Pass on this guide in the event of change of ownership of the installation site.
4. Follow all warnings, cautions and instructions contained in this guide.
5. The plumbing installation must comply with the requirements of UK Water Regulations/Bye-laws (Scotland), Building Regulations or any particular regulations and practices, specified by the local water supplier. **The installation should be carried out by a plumber or contractor who is registered or is a member of an association such as:**
 - i) Institute of Plumbing (IOP), throughout the UK.

- ii) National Association of Plumbing, Heating and Mechanical Services Contractors (NAPH & MSC), England and Wales.
 - iii) Scottish and Northern Ireland Plumbing Employers' Federation (SNIPEF), Scotland and Northern Ireland.
6. Anyone who may have difficulty understanding or operating the controls of any appliance should be attended whilst operating. Particular consideration should be given to the young, the elderly, the infirm, or anyone inexperienced in the correct operation of the controls.

The use of the word “failsafe” to describe the function of a thermostatic mixing valve is both incorrect and misleading. In keeping with every other mechanism it cannot be considered as being functionally infallible.

Provided that the thermostatic mixing valve is installed, commissioned, operated within the specification limits and maintained according to this Manual, the risk of malfunction, if not eliminated, is considerably reduced.

Malfunction of thermostatic mixing valves is almost always progressive in nature and will be detected by the use of proper temperature checking and maintenance routines.

Certain types of system can result in the thermostatic mixing valve having excessive ‘dead-legs’ of pipework. Others allow an auxiliary cold water supply to be added to the mixed water from the mixing valve. Such systems can disguise the onset of thermostatic mixing valve malfunction.

Ultimately, the user or attendant must exercise due diligence to make sure that the delivery of warm water is at a stable, safe temperature. This is particularly important in such healthcare procedures as supervised bathing of patients unable to respond immediately to unsafe temperatures.

Safetherm Options

The following table indicates temperature control options available for the Safetherm.

Installation	Temperature Adjustment	Description
Panel	Adjustable Temperature Control	Safetherm
Basin	Adjustable Temperature Control	

PACK CONTENTS CHECKLIST



Tick the appropriate boxes to familiarize yourself with the part names and to confirm that the parts are included.

Safetherm Panel

- 1 x 2.5 mm A/F Hexagon Wrench



- 1 x 3 mm A/F Hexagon Wrench



- 1 x 'O' Key

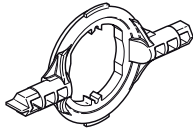

- 2 x Inlet Connector

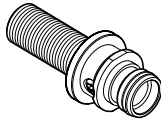

- 2 x Screw on Shroud

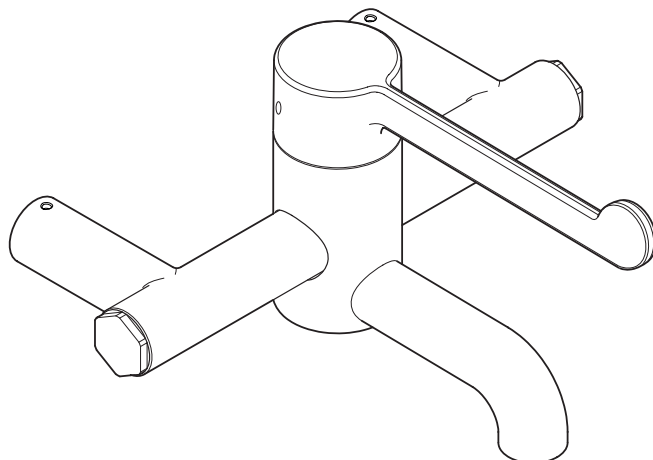
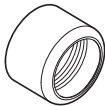

- 1 x Flow Straightner



- 2 x Grub Screws



- 2 x Compression Nuts



- 2 x Back Nuts



- 2 x Olives



- 1 x Flat Face Connector Pack



- 2 x Heat Shroud



- 1 x Safetherm Tap Control (Panel Mount)

- 1 x TMV3 Requirements Manual

Safetherm Basin

2 x Compression Nuts



2 x Back Nuts



2 x Olives



2 x 'O' Seals

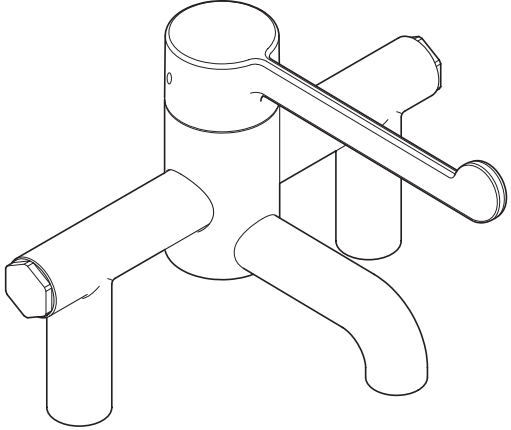

1 x Safetherm Tap Control (Basin Mount)

2 x Extension Tube



2 x Extension Sleeve

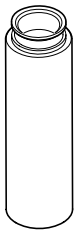

1 x TMV3 Requirements Manual

1 x Angled Flow Straigtenner



2 x Back Plate



2 x Large Rubber Washer



2 x Deck Mount Plate

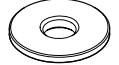

2 x Deck Mount Ring

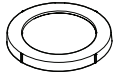

2 x 'O' Seals



2 x Grub Screws



1 x 2.5 mm A/F Hexagon Wrench



1 x 3 mm A/F Hexagon Wrench



1 x 'O' Key

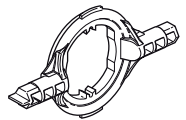

1 x Flat Face Connector Pack



2 x Inlet Connector

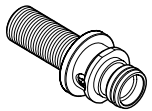

2 x Concealing Shroud

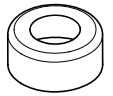

2 x Heat Shroud



SPECIFICATIONS

For Type 3 Valves, the supply conditions specified in the TMV3 Requirements Manual take precedence over the operating parameters which follow.

Pressures

- Max Static Pressure: **10 Bar**.
- Max Maintained Pressure: **5 Bar**.
- Min Maintained Pressure (Gravity System): **0.1 Bar**.
(0.1 bar = 1 Metre head from cold tank base to tap outlet).
- For optimum performance supplies should be nominally equal.

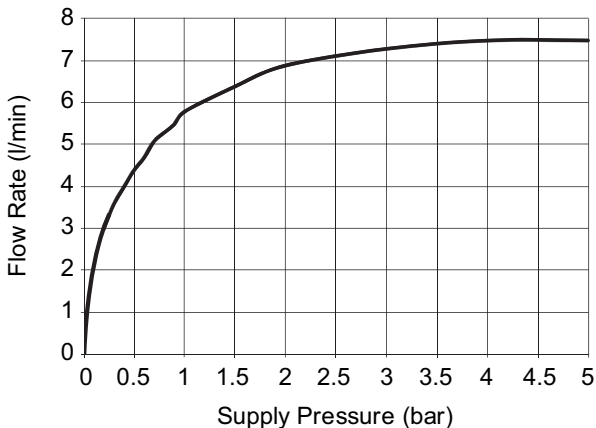

Temperatures

- Factory Pre-set (Blend): **41°C**.
- Optimum Thermostatic Control Range: **35°C to 43°C** (achieved with supplies of 15°C cold, 65°C hot and nominally equal pressures).
- Recommended Hot Supply: **60°C to 65°C Note!** The thermostatic control can operate at higher temperatures for short periods without damage, however this could detrimentally affect thermostatic performance. For safety and performance reasons it is recommended that the maximum hot water temperature is limited to 65°C.
- Cold Water Range: up to **25°C**.
- Minimum Recommended Differential between Hot Supply and Outlet Temperature: **12°C**.
- Please refer to section: '**Type 3 Valves - Application** for Type 3 Valves.

Thermostatic Shut-down

- For safety and comfort the thermostat will shut off the thermostatic control **within 2 Seconds** if either supply fails (achieved only if the blend temperature has a minimum differential of 12°C from either supply temperature).

Connections

- Inlets: 15 mm Compression or 1/2" BSP flat face.
- Standard connections are: **hot - left, cold - right**.
- The inlet connectors are fixed at 200 mm centres.

Important Points

1. The installation, commissioning and maintenance of this product must be carried out in accordance with the instructions given in the manual, and must be conducted by designated, qualified and competent personnel.
2. Installations must comply with all Local/National Water Supply Authority Regulations/Bye-laws, and Building and Plumbing (UK:BS6700) Regulations.
3. Rada products are precision engineered and should give continued and superior performance, provided:
 - a. They are installed, commissioned, operated and maintained in accordance with these recommendations
 - b. Periodic attention is given as necessary to maintain the product in good functional order. Recommended guidelines are given in section: **'Maintenance'**.
4. **Warning!** Continued use of this product in conditions outside the limits listed in this section can severely affect the performance and reduce the effective service life, and can present potential risk to users.
5. Suitable for use with most modulating instantaneous gas water heaters.
For information on other specific applications or suitability, contact Kohler Mira Ltd or your local agent.
6. **Disinfectants and Other Chemicals:** In applications where system chemical disinfection is practised, chlorine can be used (calculated chlorine concentration of 50 mg/l (ppm) maximum in water, per one hour dwell time, at service interval frequency). Such procedures must be conducted strictly in accordance with all relevant Guidelines/Approved Codes of Practice.

Note! the use of ammonia or any ammonia type chemicals (e.g. as found in some solder fluxes) can attack brass material which may lead to premature failure.

If in any doubt as to the suitability of chemical solutions, contact Kohler Mira Ltd or your local agent.

Normal Operating Conditions are considered as:

1. Inlet dynamic pressures nominally balanced to within ten percent of each other during flow.
2. A differential of approximately 50°C between the hot and cold inlet temperatures, and with differentials of 15 - 35°C between the blend setting and either supply.
3. **Daily usage of 1 - 6 hours.**
4. Installation and usage environment not subject to extremes of temperature, unauthorised tampering or willful abuse.

Dimensions

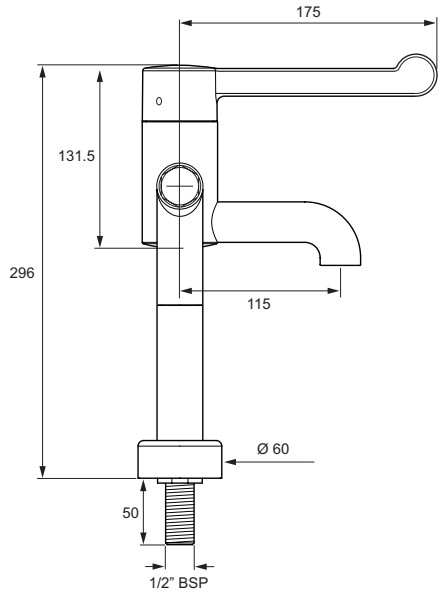
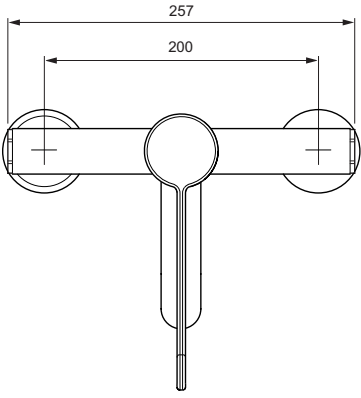
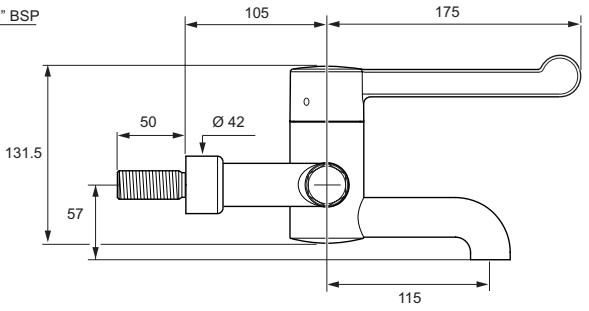
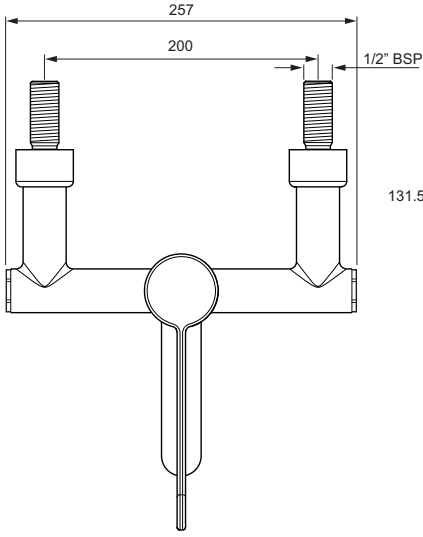

All dimensions are nominal and in millimetres

1139248-W2-H

INSTALLATION

1. Before commencing, make sure that the installation conditions comply with the information given in section: '**Specifications**'. For Type 3 valves, refer to the the TMV3 Requirements Manual.
2. Care must be taken during installation to prevent any risk of injury or damage.
3. Layout and sizing of pipework **MUST** be such that nominally equal inlet supply pressures are achieved and effects of other draw-offs are minimised.
4. The Rada Safetherm is suitable for installation as part of a gravity-fed plumbing system. Minimum inlet pressures of 0.1 bar (1 metre head) are required, though inlet pressures of 1 bar (10 metre head) are recommended for optimum performance. If minimum inlet pressures are not available then it will be necessary to install a pump.
5. When used with a **high pressure system above 5 bar maintained pressure**, a pressure reducing valve will be necessary. It is important that the system pressures are within the range specified for the Safetherm.
If the system pressure is not known then the system pressure **MUST** be measured.
Pressures are those present at the inlet to the appliance either whilst running (maintained) or in the off state (static). Nearby hot and cold taps connected to the same proposed feed pipes as the appliance can be used to measure the static pressure. No other fitting or appliance should be in use at this time.
6. Conveniently situated isolating valves **MUST** be fitted to the supply pipework.
7. If the control is to be used with a fully modulating multipoint water heater, fully modulating combination boiler, thermal store or unvented system an expansion vessel must be fitted to accommodate the expansion of water in the domestic hot water supply (this may already be part of the system, check the details on the boiler/heater or contact the boiler/heater manufacturer).
8. Supply pipes **MUST** be flushed to clear debris before connecting the control.
Note! The Rada Safetherm is supplied with **hot left** and **cold right** inlet connections as standard.

Panel Mounting

Warning! Make sure that there are no buried cables or pipes in the wall before drilling.

1. Temporarily assemble the inlet connectors with the inlet elbows tightening both grub screws with a 2.5 mm hexagonal key.

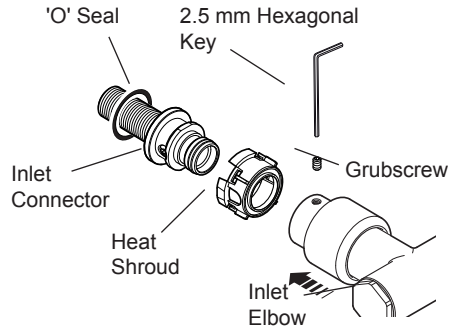

2. Mark the positions of the holes for the inlet connectors on the panel and then drill two $\text{Ø}21$ mm holes for the inlet connectors.

Important! The position of the Rada Safetherm must provide a minimum gap of 25 mm between the spout outlet and the spill over level of a basin with a fluid category 3 risk, or a minimum gap of 30 mm with a fluid category 5 risk.

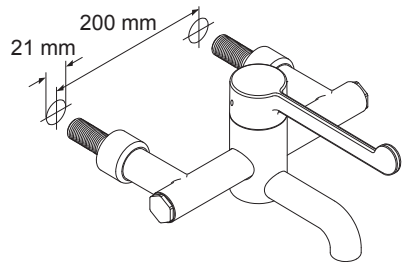

3. Fit the 'O' seal to the rear face of the inlet connectors then install the inlet connectors through the $\text{Ø}21$ mm holes and loosely fit the back nuts.

4. Install the hot and cold supply pipework ensuring that the pipe ends align with the inlet connectors.

5. Fit the compression nuts and olives or the flat face connectors onto the supply pipes and connect the supply pipes to the inlet connectors. Confirm that the inlet connectors are level and the specified distance apart then use a suitable wrench to tighten the back nuts.

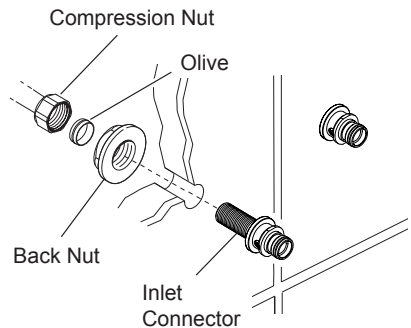
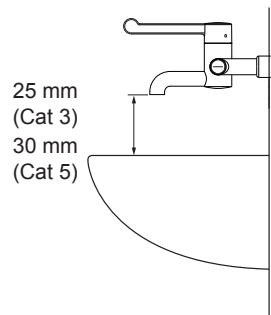

Note! Use the flats provided on the inlet connectors to hold the connectors in position while tightening the back nuts.

- 6. Turn the isolators to the **OFF** position then turn on the water supply and check for leaks.

Note! The isolation valve is located in the body of the inlet connector. To isolate the water supply, turn the screw slot on the isolation valve a quarter turn.

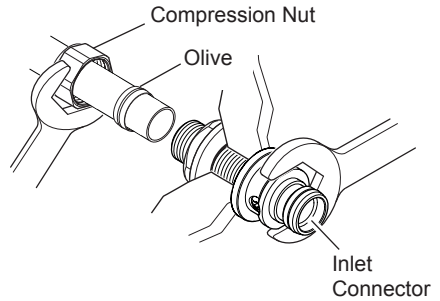

- 7. Fit the heat shrouds to the inlet connectors. **Note!** The access window of the heat shroud must align with the isolation valve.

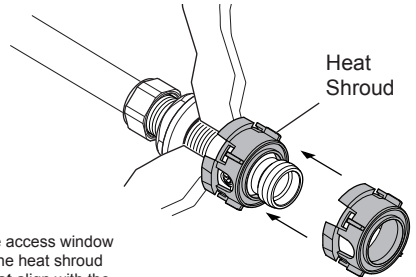

The access window of the heat shroud **must** align with the isolation valve.

- 8. Slide the Screw on shrouds along the elbows then fit the tap control to the inlet connectors. Use a 2.5 mm hexagonal key to tighten both grub screws and secure the tap control to the inlet connectors.

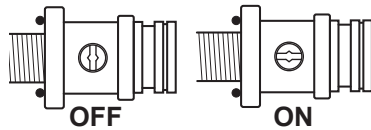

- 9. Turn the isolators to the **ON** position and check for leaks.

- 10. Slide the Screw on shroud back and screw onto the heat shroud to conceal the grub screws.

11. Important! Fit the Flow Straightener (supplied)

With a spanner screw the flow straightener with the o ring fitted into the spout. Do not over tighten

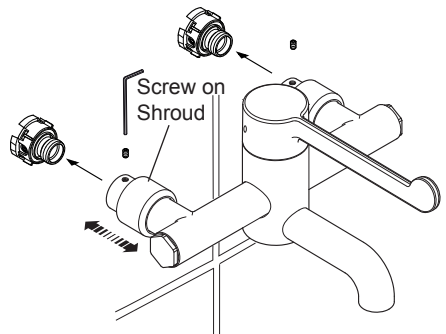

- 12. Set the maximum temperature refer to section: **'Commissioning - Maximum Temperature Setting'**.

Basin Mounting

1. Slide the 'O' seal along the threaded section of the inlet connector then screw the inlet connector and the deck mount plate together.
2. Insert the inlet connectors through the basin holes.
3. Fit the large rubber washers and back plates then loosely fit the back nuts.
4. Install the hot and cold supply pipework. Make sure that the pipe ends align with the inlet connectors.
5. Install the compression nuts and olives or the flat face connectors onto the supply pipes and connect the supply pipes to the inlet connectors. Confirm that the inlet connectors are the specified distance apart then use a suitable wrench to tighten the back nuts. **Note!** Use the flats provided on the inlet connectors to hold the connectors in position while tightening the back nuts.
6. Turn the isolators to the **OFF** position then turn on the water supply and check for leaks. **Note!** The isolation valve is located in the body of the inlet connector. To isolate the water supply, turn the screw slot on the isolation valve a quarter turn.

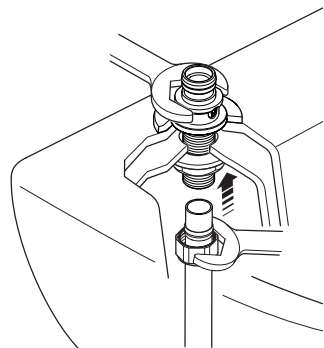
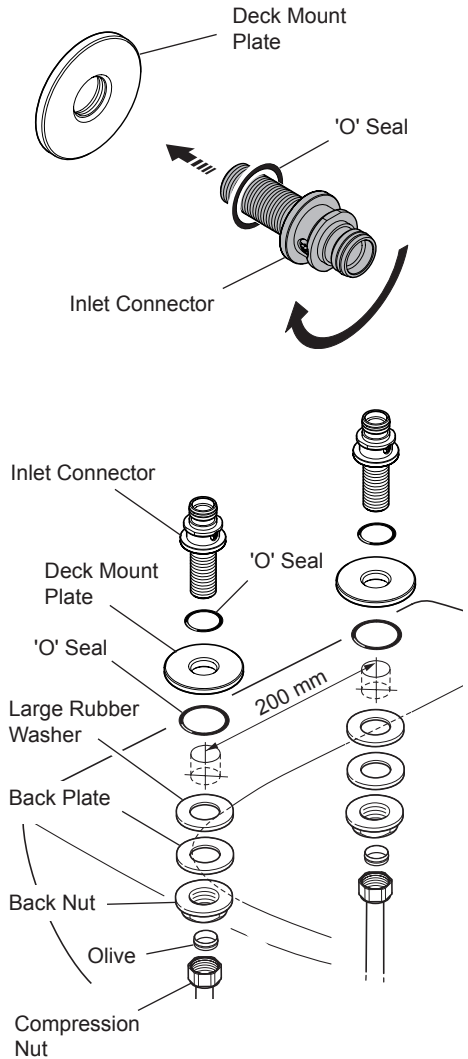

7. Fit the deck mount rings over the inlet connectors.
8. Fit the heat shrouds to the inlet connectors. **Note!** The access window of the heat shroud must align with the isolation valve.
9. Slide the elbow sleeves into the elbow extensions, and place them onto the heat shrouds on the basin.
10. Screw the elbow sleeves (through the elbow extensions) onto the inlet connectors and tighten with a 10 mm hexagonal key. Slide the concealing shrouds onto the elbow extensions.
11. Pick up the product and loosen the grub screws securing the elbows. Twist the elbows so they align with the elbow extensions.
12. Fit the tap control onto the elbow extensions pushing down to make sure it is correctly seated. Ensure that the spout is horizontal, retighten elbows securing grub screws. Use a 2.5 mm hexagonal key to tighten the grubscrews and secure the tap control to the inlet connectors.
13. Turn the isolators to the **ON** position and check for leaks.
14. Slide the concealing shroud back to the basin surface to conceal the grubscrews.
15. **Important!** Fit the Angled Flow Straightener (supplied)
With a spanner screw the angled flow straightener with the o ring fitted into the spout. Do not over tighten. Then undo it until the angle of flow points outwards towards the user.
16. Set the maximum temperature refer to section: '**Commissioning - Maximum Temperature Setting**'.

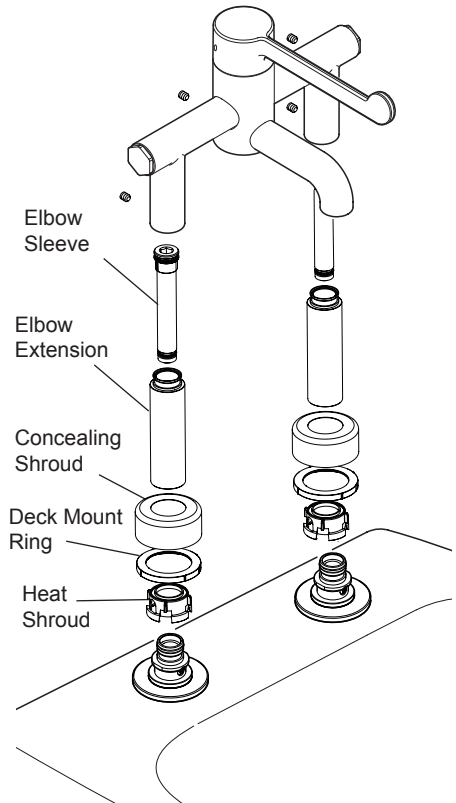
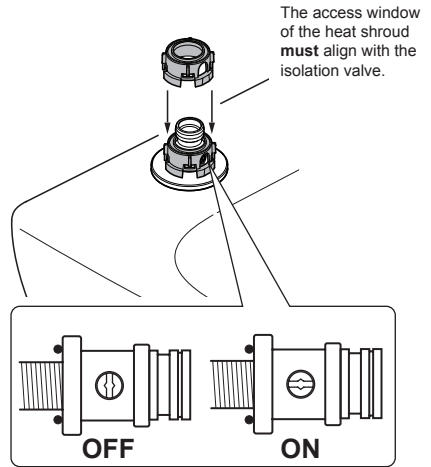

OPERATION

Rada Safetherm uses a single sequential control lever for on/off and temperature control.

The control lever operates anti-clockwise in the following sequence:

- Off
- On
- Cool
- Warm
- Maximum Preset Temperature

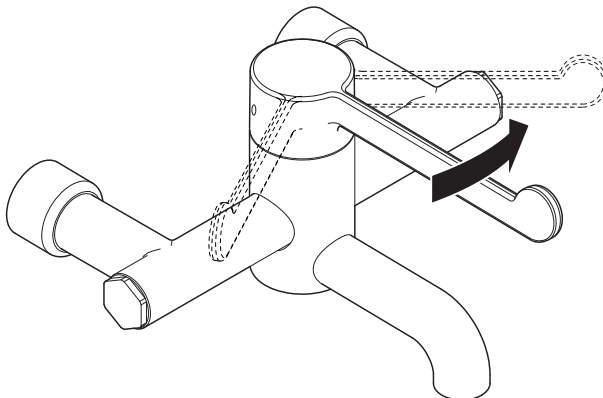
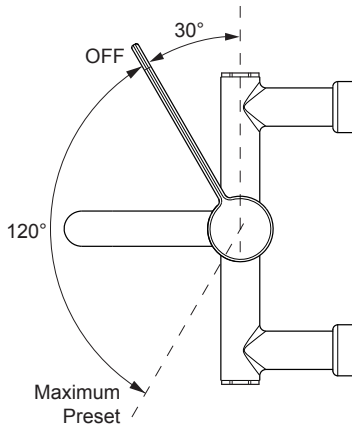

COMMISSIONING

Commissioning must be carried out in accordance with these instructions, and must be conducted by designated, qualified and competent personnel.

Exercising the Thermostat

Thermostatic mixing valves with wax thermostats are inclined to lose their responsiveness if not used. Valves which have been in storage, installed but not commissioned, or simply not used for some time should be exercised before setting the maximum temperature or carrying out any tests.

Note! Make sure that the hot and cold water supplies are available at the inlets.

1. Move the tap control lever rapidly from cold to hot and hot back to cold several times, pausing at each extreme.
2. Operate the tap control and check:
 - a. Flow rate is sufficient for the purpose
 - b. Temperature(s) obtainable are acceptable.
3. Adjust the temperature of the mixed water in accordance with the instructions (refer to the section: '**Commissioning: Maximum Temperature Setting**'). For Type 3 valves refer to the table in the TMV3 Requirements Manual.

It is advisable to establish a performance check at this time, which should be noted for future reference as part of a Planned Maintenance Programme. The procedure should be chosen to imitate both typical and difficult operating conditions, such as any supply pressure fluctuations that may be likely. An ideal method is to locate another outlet on the common cold water supply close to the mixing valve (operating this outlet should cause a drop in supply pressure), and note the subsequent effect on blend temperature (should be no more than a 2° C change).

Maximum Temperature Setting

Before using the thermostatic control the maximum temperature must be checked to make sure that it is at a safe level. It has been preset to approximately 41°C at the factory but due to variations in site conditions the maximum temperature may need adjustment.

Note! Make sure that the hot water temperature is at least 55°C and that there is sufficient supply.

1. Turn the tap to the maximum temperature and maximum flow setting (i.e. fully anticlockwise) and allow the temperature to stabilise.
If the temperature is too hot or too cold adjust as follows:

2. Carefully remove the concealing cap, unscrew the grub screw using a 2.5 mm hexagonal key (supplied) and pull off the control lever.
3. Unscrew the hub retaining screw with a 2.5 mm hexagon key.

Note! Do not remove the hub.
4. Insert the 2.5 mm hexagonal key into the centre of the spindle and engage with the recessed temperature adjusting screw.
5. Rotate the hexagonal key until the required maximum temperature is obtained at the tap outlet. Anticlockwise to increase the temperature, or clockwise to decrease the temperature ($\frac{1}{4}$ turn = approximately 1°C).

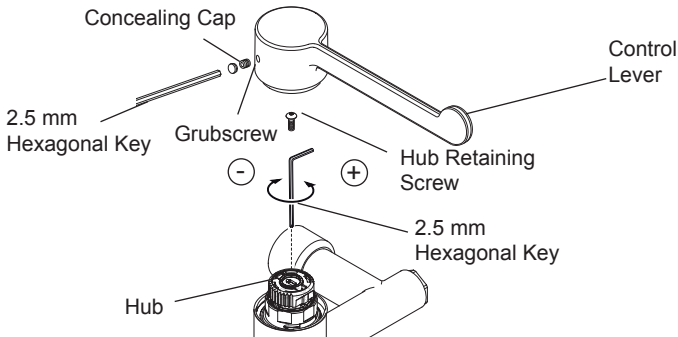

Maximum Temperature Setting

6. Once the desired maximum blend temperature has been achieved turn off the tap control by rotating the hub fully clockwise.

Note! Do not remove the hub.
7. Refit the hub retaining screw.
8. Refit the control lever.
9. Push the control lever down (1), and tighten the grub screw (2) and refit the concealing cap.

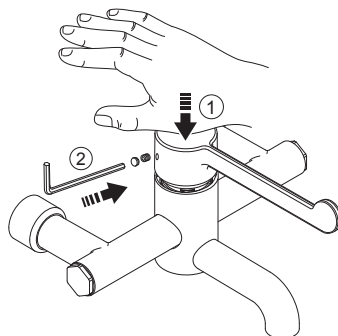

10. Check that the temperature is correct.

FAULT DIAGNOSIS

Symptom	Cause/Rectification
1. Only hot or cold water from tap outlet.	<ul style="list-style-type: none"> a. Inlet supplies reversed. Check. b. No hot water reaching control. Check. c. Check filters and inlet fittings for blockage. d. Installation conditions continuously outside operating parameters: refer to the section: 'SPECIFICATIONS' and symptom 2.e. e. Refer to symptom 5.
2. Fluctuating or reduced flow rate.	<p>Normal function of thermostatic control when operating conditions are unsatisfactory;</p> <ul style="list-style-type: none"> a. Check filters and inlet/outlet fittings for flow restriction. b. Make sure that minimum flow rate is sufficient for supply conditions. c. Make sure that maintained inlet pressures are nominally balanced and sufficient. d. Make sure that inlet temperature differentials are sufficient. e. (Subsequent to rectification of supply conditions) Check thermostatic performance; renew thermostatic cartridge if necessary.
3. No flow from tap outlet.	<ul style="list-style-type: none"> a. Check filters and inlet/outlet fittings for blockage. b. Hot or cold supply failure; thermostat holding correct shutdown function: rectify, and refer to symptom 2.e. c. Thermostatic cartridge faulty. Check and renew if necessary.
4. Blend temperature drift.	<p>Indicates operating conditions changed.</p> <ul style="list-style-type: none"> a. Refer to symptom 2. b. Hot supply temperature fluctuation. c. Supply pressure fluctuation. d. Thermostatic cartridge faulty. Check and renew if necessary.
5. Hot water in cold supply or vice versa.	<p>Indicates check valves require maintenance, refer to the section: 'MAINTENANCE'.</p>

Symptom	Cause/Rectification
<p>6. Maximum blend temperature setting too hot or too cool.</p>	<p>a. Indicates incorrect maximum temperature setting; refer to the section: 'COMMISSIONING'.</p> <p>b. As symptom 4.</p> <p>c. As symptom 5.</p>
<p>7. Water leaking from control body.</p>	<p>Seal(s) worn or damaged.</p> <p>a. Obtain service pack and renew all seals.</p> <p>b. If leak persists renew thermostatic cartridge.</p>
<p>8. Control Lever stiff to operate.</p>	<p>a. Impaired movement of internal components. Renew the thermostatic cartridge.</p> <p>b. Supply pressures too high. Fit pressure reducing valve. Refer to the section: 'SPECIFICATIONS' for acceptable operating pressures.</p> <p>c. Pressure build up. This may be due to domestic hot water expansion. Fit domestic hot water expansion vessel (available from your local stockist). If one already fitted, it may be deflated and require repressurization.</p>
<p>9. Drip from tap outlet.</p>	<p>a. A small amount of water may be retained in the valve after the tap control has been turned off. This is quite normal and should drain after a few minutes.</p>
<p>10. Safe therm noisy during operation.</p>	<p>a. The inlet supply pressures may be unbalanced. Fit a drop tight Pressure Reducing Valve (PRV) just after the incoming mains stopcock, effectively balancing the hot and cold supply pressures. Ideally set the PRV to 3.0 bar.</p> <p>b. The inlet supply pressures may be high. The maximum maintained pressure should not exceed 5 bar. If greater, fit a drop tight PRV installed as detailed above.</p>

MAINTENANCE

Planned Maintenance

Malfunction of Thermostatic Mixing Valves is almost always progressive in nature and will be detected by the use of proper temperature checking and maintenance routines.

Certain types of system can result in the valve having excessive 'dead-legs' of pipework, or auxiliary cold water supply added to the mixed water from the valve. Such systems can disguise the onset of thermostatic mixing valve malfunction and should not be used.

We recommend a preventative maintenance procedure based on site conditions and the risk to the user. All results must be recorded in a log book.

Healthcare

Healthcare applications are hospitals, aged person facilities, residential care homes, etc. and any other applications where the user is similarly at risk.

Ultimately, the user or attendant must exercise diligence to make sure that the delivery of warm water is at a stable, safe temperature. This is particularly important in such procedures as supervised bathing where patients are unable to respond immediately to unsafe temperatures.

Commercial

Check for correct blend setting every 6 months.

Follow the In-Service Test Procedure every 12 months.

Critical Components

Irrespective of supply and usage conditions or the evidence of in-service tests, critical components should be replaced at intervals of no more than 5 years.

Note! During the replacement of critical components, it may be necessary to replace other non-critical components.

Cleaning

External surfaces can be cleaned with products associated with basin cleaning referenced in the NHS cleaning manual.

Caution: Plated or plastic fittings should only be cleaned using a mild detergent or soap solution and wiped dry with a soft cloth.

Thermostatic Cartridge Renewal

Important! Use only silicone-based lubricants when reassembling.

1. Isolate the water supplies using the ball valves fitted in the inlet connectors.
2. Turn on the control lever to relieve water pressure and to drain any residual water.
3. Carefully remove the concealing cap.
4. Unscrew the grub screw using a 2.5 mm hexagonal key (supplied) and pull off the control lever.
5. Pull off the bearing.
6. Use a suitably sized wrench to unscrew the brass cartridge retaining nut then pull out the thermostatic cartridge.

7. Pull off the cardboard shroud from the new cartridge.

Caution! The cartridge is factory set, **do not** turn the cartridge end.

8. Make sure that the tap control body is clean and free from limescale and carefully push the replacement cartridge into the body, aligning the cartridge lugs into the correct body slots (1). Secure by tightening the brass cartridge retaining nut (2).

Important! Take care when fitting the cartridge as damage to the cartridge inlet seals may result in water dripping from the tap control outlet.

9. Refit the bearing and control lever.
10. Push the control lever down (3) and using the 2.5 mm hexagonal key tighten the grub screw (4).
11. Refit the concealing cap.
12. Restore the hot and cold water supplies and check for leaks.
13. This completes the replacement of the thermostatic cartridge and/or hub.

Go to section: '**Commissioning**'.

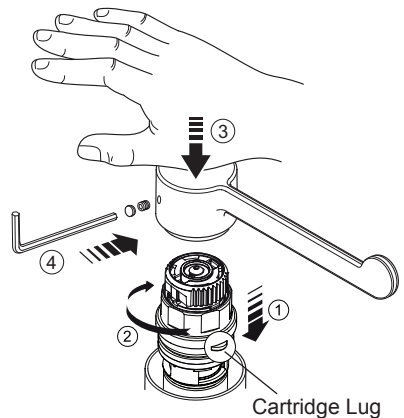
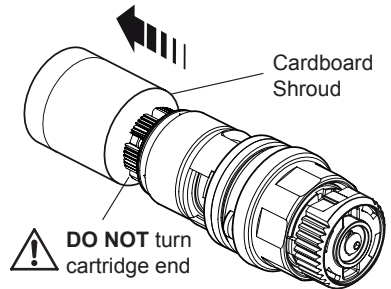
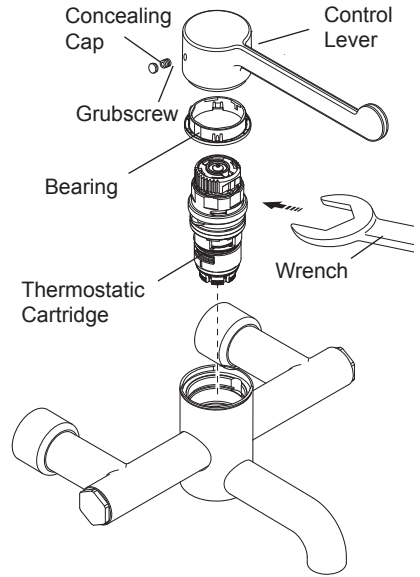

Cartridge Renewal

Filter Renewal

Should the filters require cleaning or renewal then the following procedure should be followed (refer to the following illustration).

Important! Use only silicone-based lubricants when reassembling.

1. Isolate the water supplies using the ball valves fitted in the inlet connectors and operate the lever to drain the tap control of any residual water.
2. Use your fingers or a screwdriver to carefully prise the concealing cap from the elbow.
3. Use the 'O' key supplied or a 12 mm hexagonal wrench to unscrew the filter plug.
4. Pull out the filter cap and filter from the elbow using a pair of long nosed pliers if necessary.
5. The filters may be cleaned under a jet of water, or renewed. Make sure there is no debris or damage to the 'O' seals.
6. Refit the filter and filter cap.
7. Tighten the filter plug.
8. Restore the hot and cold water supplies and check for leaks.
9. Refit the concealing cap to the elbow.
10. Restore the water supplies using the ball valves fitted in the inlet connectors and make sure there are no leaks.

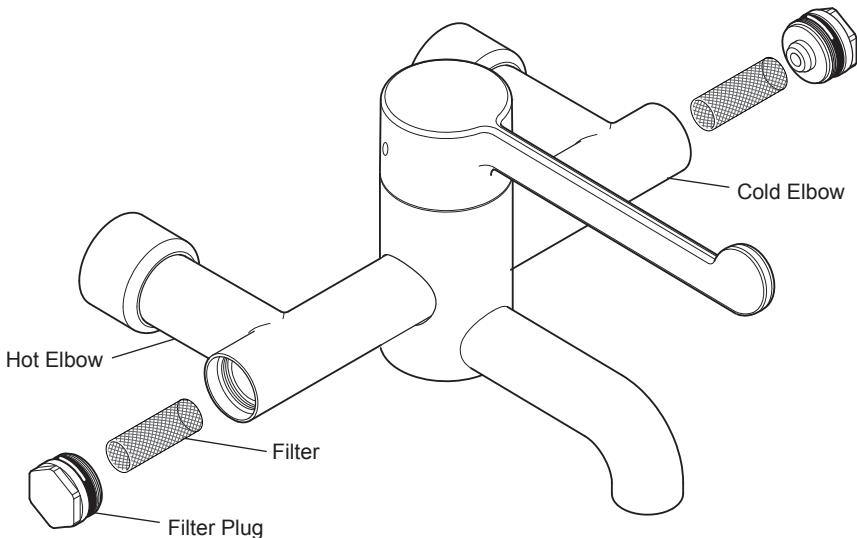

Filter Renewal

Checkvalve Cartridge Renewal

1. Isolate the water supplies using the ball valves fitted in the inlet connectors and operate the lever to drain any residual water.
2. Use a 2.5 mm hexagonal key to loosen the grub screws and release the main tap control body from the inlet connectors.
3. Remove the tap control.
4. Use a 2.5 mm hexagonal key to loosen the grub screws, then remove the elbows from the tap control body.
5. The checkvalve cartridge is seated between two seals and as the elbow is removed may be retained in the elbow or the main body, either:
 - Pull the checkvalve cartridge to remove it from the body, or
 - If the checkvalve cartridge remains in the elbow use a pair of long nosed pliers to remove it.
6. Discard the original checkvalve cartridge then push the replacement checkvalve into the body making sure the 'O' seal engages fully.
7. Slide the elbow over the checkvalve cartridge pushing firmly to relocate the elbow with the seals in the tap body.
8. Retighten the grub screw to secure the elbow to the tap body.
9. Repeat this process to replace the other checkvalve cartridge.
10. Refit the tap control to the inlet connectors and retighten the grub screws.
11. Restore the water supplies and make sure there are no leaks.

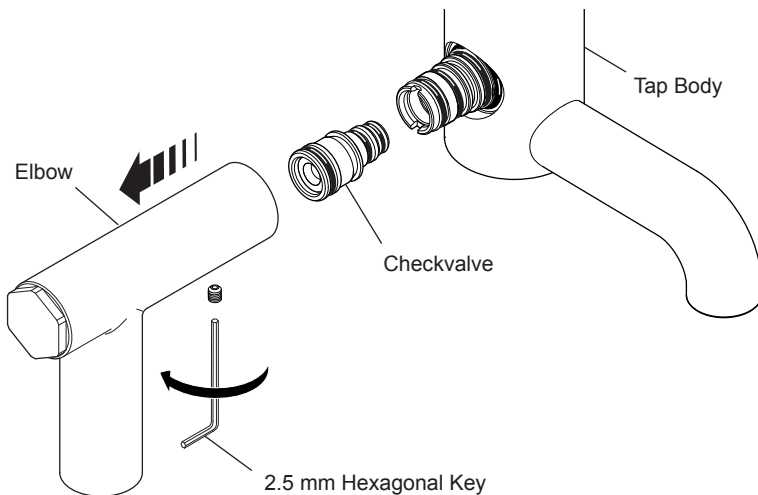

SPARE PARTS

Safetherm Spare Parts Diagram (Panel Mount)

1704.193

Screw Pack - Identified A

1704.194

Seal Pack - Identified B

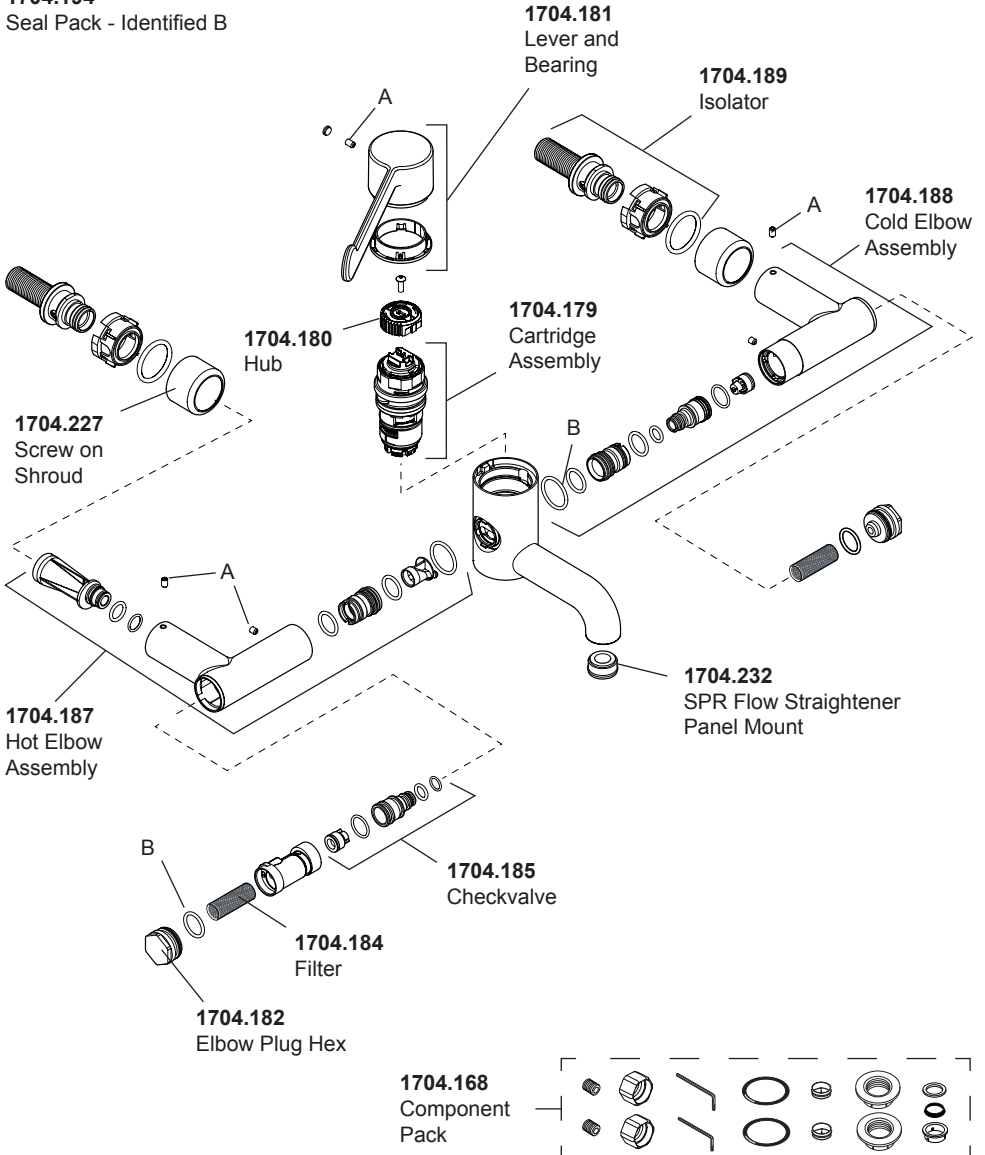

Accessories

1704.196 - Pall Filter Adapter

Safetherm Spare Parts Diagram (Basin Mount)

1704.193
Screw Pack - Identified A

1704.194
Seal Pack - Identified B

1704.181
Lever and
Bearing

1704.179
Cartridge
Assembly

1704.188
Cold Elbow
Assembly

1704.185
Checkvalve

1704.184
Filter

1704.182
Elbow
Plug Hex

1704.187
Hot Elbow
Assembly

1704.228
Angled Flow
Straightener
Basin Mount

1704.195
Concealing
Shroud

1704.189
Isolator

1704.178
Basin Mount
Component
Pack

1704.168
Component
Pack

Accessories
1704.196 - Pall Filter Adapter

1139248-W2-H

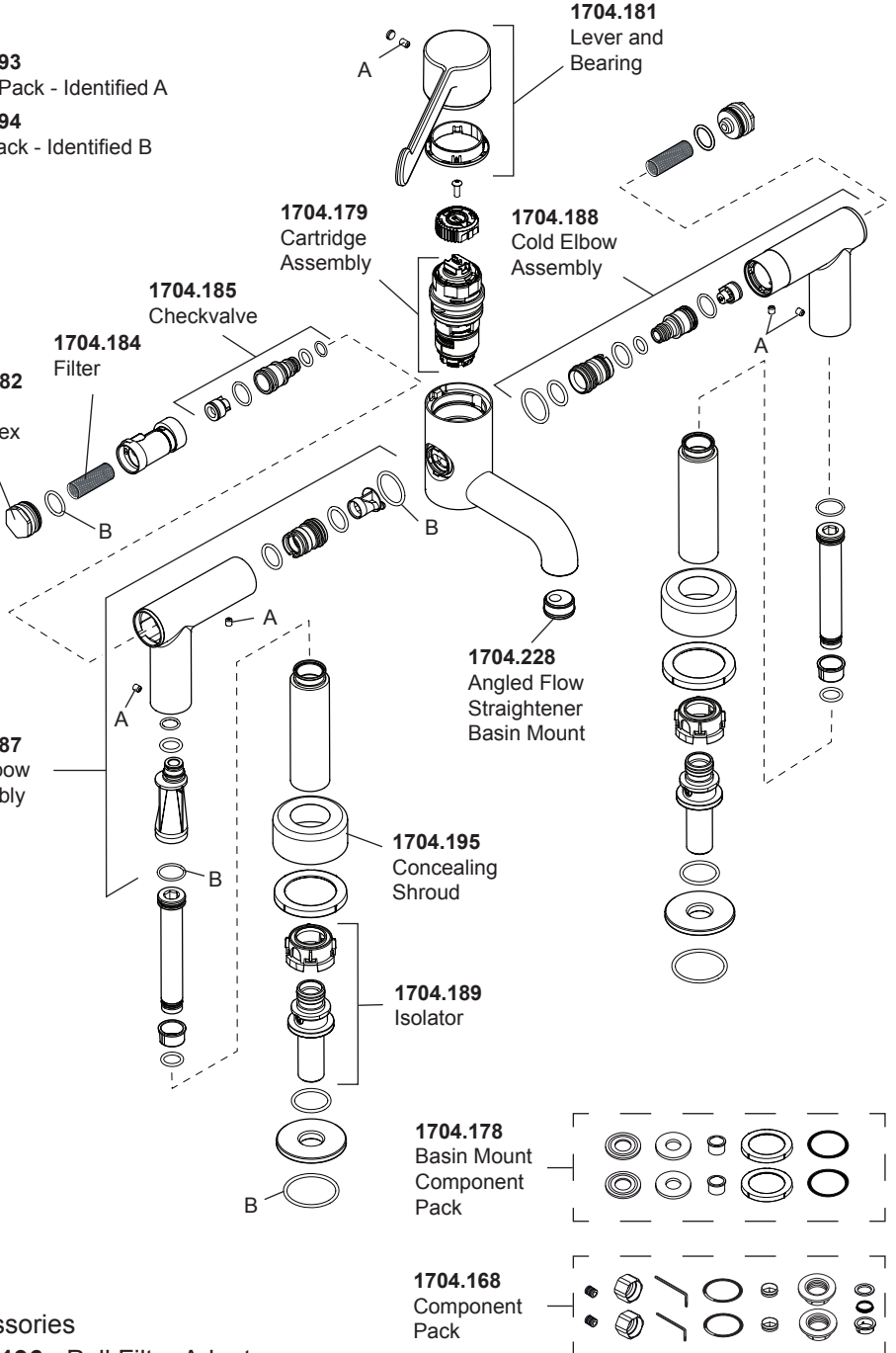

NOTES

CUSTOMER CARE

Guarantee

Your product has the benefit of our manufacture's guarantee which starts from date of purchase. Within the guarantee period we will resolve defects in materials or workmanship, free of charge, by repairing or replacing parts or product as we may choose.

This guarantee is in addition to your statutory rights and is subject to the following conditions:

- The product must be installed and maintained in accordance with the instructions given in this user guide.
- Servicing must only be undertaken by us or our appointed representative. **Note!** If a service visit is required the product must be fully installed and connected to services.
- Repair under this guarantee does not extend the original expiry date. The guarantee on any replacement parts or product ends at the original expiry date.
- For shower fittings or consumable items we reserve the right to supply replacement parts only.

The guarantee does not cover:

- Call out charges for non product faults (such as damage or performance issues arising from incorrect installation, improper use, inappropriate cleaning, lack of maintenance, build up of limescale, frost damage, chemical attack, corrosion, system debris or blocked filters) or where no fault has been found with the product.
- Water or electrical supply, waste and isolation issues.
- Compensation for loss of use of the product or consequential or indirect loss of any kind.
- Damage or defects caused if the product is repaired or modified by persons not authorised by us or our appointed representative.
- Routine maintenance or replacement parts to comply with the requirements of the TMV2 or TMV3 healthcare schemes
- Accidental or wilful damage.
- Products purchased ex-showroom display.

What to do if something goes wrong

If your product does not work correctly refer to this manual for fault diagnosis and check that it is installed and commissioned in accordance with our instructions. If this does not resolve the issue, contact us for help and advice.



Technical Helpdesk Service

Contact our Customer Services Team for product advice, to purchase spare parts or accessories or to set up service visit. You can contact us via phone or e-mail - contact details below. Please provide your model name, power rating (if applicable) and date of purchase.



Rada Website (www.radacontrols.com)

From our website you can view our full product catalogue or download a brochure.



Spares and Accessories

We hold the largest stocks of genuine Rada spares and accessories.



Service/Repairs

No one knows our products better than our nationwide team of Service Technicians. We can carry out service or repair work to your product both during and after the guarantee period. You have the assurance of a fully trained Technician, genuine Rada spare parts and a 12 month guarantee on any chargeable work done.

Service Contracts

Regular servicing ensures your product continues to operate at the peak of performance. We offer annual or bi-annual servicing carried out by our fully trained technicians subject to site survey

To Contact Us - UK Customer Service & Specification Enquiries



0844 571 1777

Calls cost 7p per minute plus your phone company's access charge



Fax: 0844 472 3076



Email – Visit

rada_technical@mirashowers.com



By Post: Rada Controls, Cromwell Road, Cheltenham, Gloucestershire GL52 5EP

To Contact Us: Eire Only



01 531 9337



E-mail:

CustomerServiceEire@mirashowers.com

Rada is a registered trade mark of Kohler Mira Limited.

The company reserves the right to alter product specifications without notice.



rada