

# *Sense* **rada**

## Rada Sense Washbasin/Bidet T3 DMV

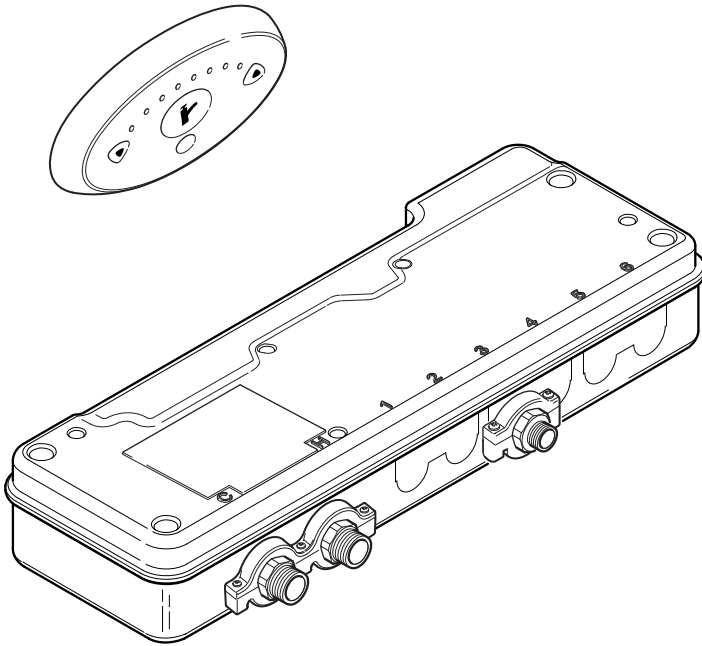

## PRODUCT MANUAL

### **IMPORTANT**

**Installer:** This Manual is the property of the customer and must be retained with the product for maintenance and operational purposes.

# CONTENTS

|                                   |           |
|-----------------------------------|-----------|
| <b>DESCRIPTION</b> .....          | <b>3</b>  |
| <b>SAFETY : WARNINGS</b> .....    | <b>4</b>  |
| <b>PACK CONTENTS</b> .....        | <b>5</b>  |
| <b>SPECIFICATION</b> .....        | <b>6</b>  |
| Standards and Approvals .....     | 6         |
| <b>INSTALLATION</b> .....         | <b>7</b>  |
| General.....                      | 7         |
| Power Supply Unit (PSU) .....     | 9         |
| Rada Sense Control Panel .....    | 10        |
| Rada Sense (DMV) .....            | 11        |
| <b>OPERATION</b> .....            | <b>12</b> |
| Duty Flush .....                  | 12        |
| Disinfection.....                 | 12        |
| <b>COMMISSIONING</b> .....        | <b>13</b> |
| Maximum Temperature Setting ..... | 14        |
| <b>MAINTENANCE</b> .....          | <b>15</b> |
| Planned Maintenance.....          | 15        |
| Cleaning .....                    | 16        |
| Checkvalves and Filters .....     | 17        |
| <b>FAULT DIAGNOSIS</b> .....      | <b>18</b> |
| Self-Diagnostic Errors .....      | 20        |
| <b>SPARE PARTS</b> .....          | <b>21</b> |
| <b>ACCESSORIES</b> .....          | <b>23</b> |
| <b>CUSTOMER SERVICE</b> .....     | <b>24</b> |

# DESCRIPTION

A range of concealed 1/2" Digital Mixing Valves (DMV) with wall mounted no-touch control panel for flow and temperature control. Functions include timed flow control, duty flush and thermal disinfection.

The suffix '3' indicates that this Digital Mixing Valve has been certified for use in UK Healthcare premises as a Type 3 valve under the BuildCert TMV3 scheme. For Healthcare installation refer to the TMV3 Requirements Manual.

The approved designations for Type 3 Valves are as follows:

| Model                     | Designations                         |
|---------------------------|--------------------------------------|
| Rada Sense Basin/Bidet T3 | HP - B    HP - W<br>LP - B    LP - W |

**Note:** Where the Rada Sense Valve is used in conjunction with a Rada Spout, which has been fitted with the Rada Anti-microbial Flow Straightener, it is recommended that a 5 litre/minute flow regulator (supplied with the Anti-microbial Flow Straightener) be fitted to the outlet of the Rada Sense Valve.

Where this is the case, Type 3 approval designations change to:

| Model                     | Designations     |
|---------------------------|------------------|
| Rada Sense Basin/Bidet T3 | HP - WE, LP - WE |

# SAFETY : WARNINGS

The function of this DMV is to deliver water consistently at a desired temperature. This requires that:

1. It is installed, commissioned, operated and maintained in accordance with the recommendations given in this manual.
2. Periodic attention is given, as necessary, to maintain the product in good functional order. Recommended guidelines are given in '**MAINTENANCE**'.
3. For Type 3 installations, valves are only to be used for applications covered by their approved designations. Refer to the **TMV3 Requirements Manual** (Available on our website [www.radacontrols.com](http://www.radacontrols.com)).
4. Using this product outside the specification limits given in this manual can present potential risk to users.
5. The electrical installation must comply with BS 7671 (commonly referred to as the IEE Wiring Regulations), all relevant national building regulations and any particular regulations and practices specified by the local electricity supply company.
6. **DO NOT** fit any form of outlet flow control i.e. trigger handset or self isolating on/off tap. Only use recommended outlet fittings.

Malfunction of thermostatic mixing valves can be detected by the use of proper temperature checking and maintenance routines.

Certain types of system can result in the thermostatic mixing valve having excessive 'dead-legs' of pipework. Such systems can disguise the onset of thermostatic mixing valve malfunction.

Ultimately, the user must exercise due diligence to ensure that the delivery of water is at a stable, safe temperature.

The use of the word 'failsafe' to describe the function of any mixing valve is both incorrect and misleading. This electronic valve incorporates additional shut-off devices to improve the level of safety however, in keeping with every other mechanism it cannot be considered as being functionally infallible.

Where chlorine disinfection is practised, **DO NOT** exceed a chlorine concentration of 50 mg/l (ppm) in water, per one hour dwell time. Such procedures must be conducted strictly in accordance with the information supplied with the disinfectant and with all relevant Guidelines/Approved Codes of Practice.

A mobile app (iOS and Android) is required to adjust factory settings, retrieve data, configure duty flush and disinfection settings and perform disinfection routines using Low Energy Wireless Bluetooth® communication. Make sure you follow all relevant Warnings & Cautions when resetting the product and operating disinfection mode.

# PACK CONTENTS

1 x Washbasin/Bidet Control Panel

 1 x Magnetic Key

1 x Suppression Ferrite

1 x Digital Mixing Valve (DMV)

 4 x Fixing Screws

 4 x Wall Plugs

 6 x Rubber Feet

 2 x Fixing Screws

 2 x Wall Plugs

1 x Power Supply Unit (PSU)

2 x Installation Templates  
DMV Installation Template, on the Packaging

# SPECIFICATION

## Standards and Approvals

This Rada Sense Digital Mixing Valve (DMV) complies with all relevant directives for CE marking.

The Rada Sense DMV is a type 1 electronic, independently mounted control for surface mounting.

For Type 3 valves, the water supply conditions are specified in the **TMV3 Requirements Manual**.

| <b>General</b>           |  |
|--------------------------|--|
| Pollution Degree         | 3  |
| Rated Impulse Voltage    | Mains Supply - 2.5 kV<br>12 V DC supply to valve - 500 V |
| Suitability for Drinking | Not suitable   |
| Connections              | Flat face union connections                              |

| <b>Pressures</b>             |  |
|------------------------------|--|
| Maximum Static Pressure      | 1000 kPa (10 bar)  |
| Minimum Pressure Loss*       | 20 kPa (0.2 bar)   |
| Supply Pressure Differential | Max. 3:1 (Equal pressure recommended)  |
| Minimum Flow Rate            | 4 L/min (<500 kPa maintained pressure)<br>6 L/min (>500 kPa maintained pressure) |

| <b>Temperatures</b>                                    |   |
|--|---|
| Factory Pre-set (Blend) Washbasin                      | Max. 41 °C, Min. 30 °C, Default at start-up 38 °C   |
| Factory Pre-set (Blend) Bidet                          | Max. 38 °C, Min. 30 °C, Default at start-up 36 °C   |
| Factory Pre-set Duty Flush                             | 41 °C <b>(Default DISABLED - use Mobile App to ENABLE)</b>  |
| Programmable Range                                     | Max. 33 - 50 °C<br>Min. 30 - 47 °C (full cold can also be selected)<br>Default at start-up 30 - 50 °C |
| Minimum Blend Temperature Differential from Hot Supply | 2 °C  |
| Optimum Thermostatic Control Range                     | 30 - 50 °C  |
| Cold Water Range                                       | 1 - 20 °C   |
| Hot Water Range  | 50 - 65 °C (85 °C for disinfection)   |
| Temperature Stability                                  | ± 1 °C at recommended supply conditions   |
| Ambient Temperature                                    | Greater than 1 °C, max. 40 °C   |
| Maximum Relative Humidity                              | 95% non-condensing  |

| <b>Electrical</b>          |                            |
|----------------------------|----------------------------|
| Supply Voltage             | 100 - 240 V RMS 50 - 60 Hz |
| Maximum Load               | 20 W at 12 V DC            |
| Control Panel Cable Length | 3 m supplied (6 m max.)    |

| <b>Times</b>               | <b>Factory Settings</b> | <b>Programmable Range</b> |
|----------------------------|-------------------------|---------------------------|
| Flow Time to Auto Shut-off | 15 seconds              | 5 seconds to 60 minutes   |
| Duty Flush Cycle           | 3 minutes               | 1 - 59 minutes            |
| Duty Flush Waiting Time    | 12 hours                | 1 - 983 hours             |

| <b>Disinfection</b> |           |                |
|---------------------|-----------|----------------|
| Minimum Temperature | 60 °C     | 60 - 85 °C     |
| Minimum Time        | 5 minutes | 0 - 50 minutes |
| Reduced Flow rate   | No        | Yes or No      |

\* The pressure loss of a system (valve and outlet fitting) is the average of the two inlet pressures minus the back pressure, where the back pressure is determined by the flow resistance of any outlet fitting.

# INSTALLATION

## General

Installation must be carried out in accordance with these instructions, be conducted by designated, qualified and competent personnel.

The installation must comply with the “Water Supply (Water Fittings) Regulations or Scottish Byelaws”, all relevant national building regulations and any particular regulations and practices specified by the local water supply company.

Before commencing, make sure that the installation conditions comply with the information given in ‘**SPECIFICATION**’. For Type 3 valves, the water supply conditions must comply with the information given in the **TMV3 Requirements Manual**.

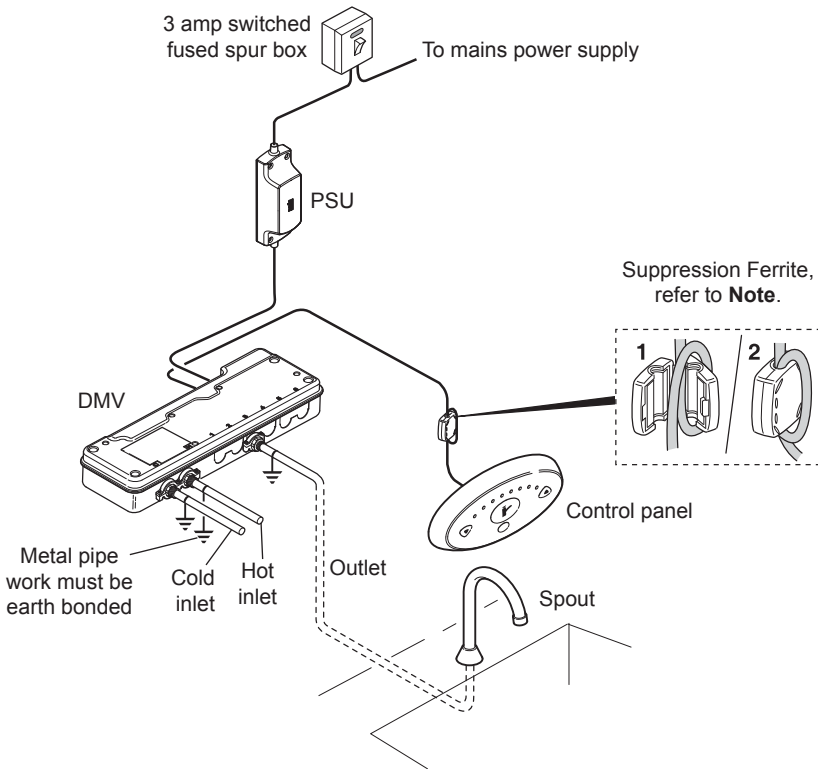

## Installation Schematic

**Note:** The Data Cable must be placed through the Suppression Ferrite and then looped around the cover. The Suppression Ferrite must be fitted as close to the Control Panel as possible.

1. The DMV and PSU must be installed in a dry area and where it will not freeze.
2. The DMV must be installed in an area where it is accessible to do any maintenance tasks e.g. removal of the cover, cleaning the strainers, etc.
3. Inlet and outlet isolating valves must be installed close to the DMV for ease of maintenance.
4. Flat face union connections must be used on the inlet and outlet connections of the DMV for ease of maintenance.
5. The use of supply-line or zone strainers will reduce the need to remove debris at each mixing valve point. The recommended maximum mesh aperture dimension for such strainers is 0.5 mm.
6. Inlet pressure tapplings which allow measurement of the inlet pressures to the mixing valve under operating conditions are particularly recommended for healthcare applications.
7. Pipework must be rigidly supported and avoid any strain on the connections.
8. Pipework dead-legs should be kept to a minimum.
9. Supply pipework layout should be arranged to minimise the effect of other outlet usage upon the dynamic pressures at the mixing valve inlets.
10. Inlet and outlet threaded joint connections should be made with PTFE tape or liquid sealant. Do not use oil-based, non-setting joint compounds.
11. To eliminate pipe debris it is essential that supply pipes are thoroughly flushed through before connection to the spout and to the Rada Sense DMV.
12. The DMV **MUST** be installed in the orientations shown and mounted on a rigid vertical surface or on top of a rigid horizontal surface.

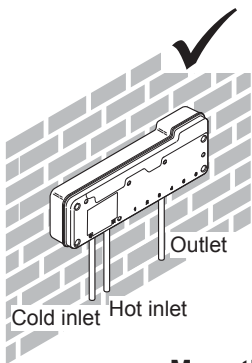

**Mounting on a Vertical Surface**

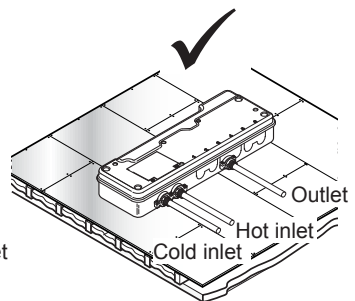
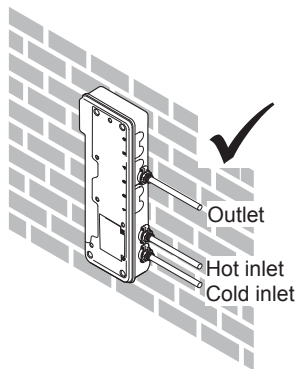

**Mounting on a Horizontal Surface**

**Note:** If the DMV is installed in a different orientation to those shown above, it may cause the DMV to malfunction e.g. cause airlocks, water ingress and could effect the thermal performance of the DMV.



The DMV **MUST NOT** be installed in the orientations shown below.

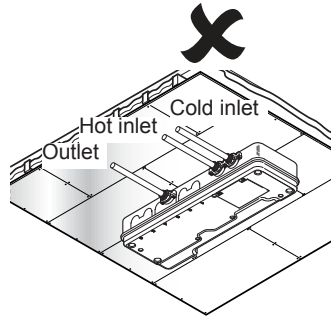
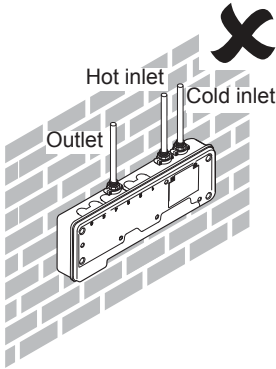

13. For the installation of your spout, refer to the **Sense Spout Kits Installation Manual**.

## Power Supply Unit (PSU)

**Warning!** Isolate mains power supply before starting installation. The PSU must be connected to a 3 amp switched fused spur box.

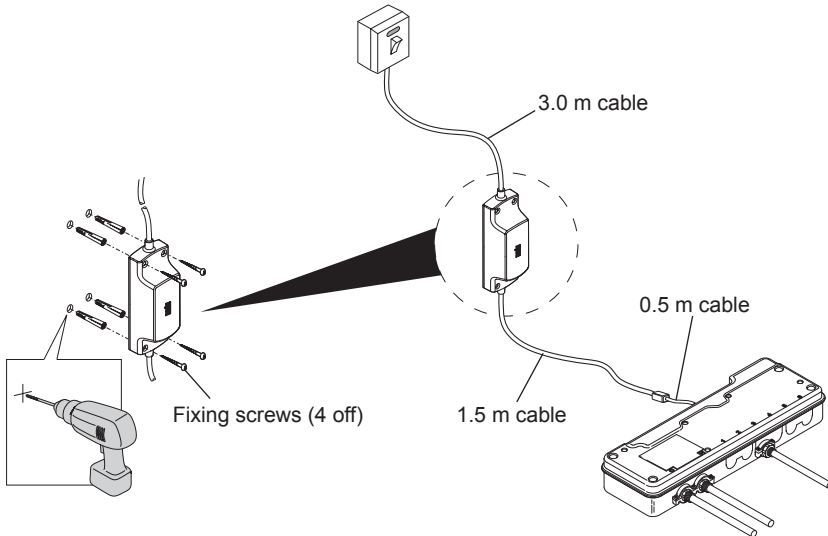

# Rada Sense Control Panel

**Note:** If the data cable is installed within a stud partition or recessed into a wall, make sure it is placed within a suitable conduit to allow easy removal during servicing. The Control Panel must only be installed onto a flat wall surface.

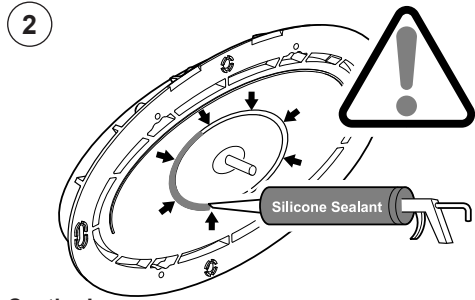
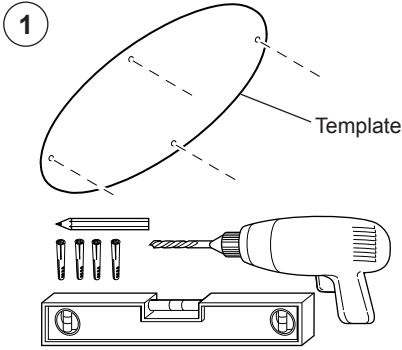

**Caution!**  
Make sure Silicone Sealant is applied in the groove on the back of the Control Panel to stop water ingress into the data cable access hole in the finished wall.

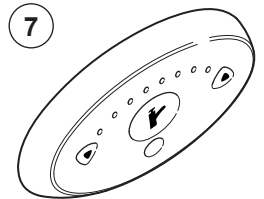
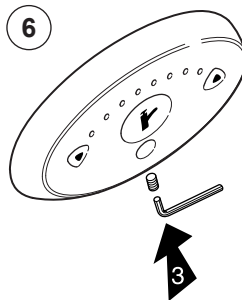
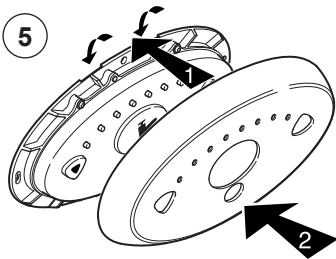
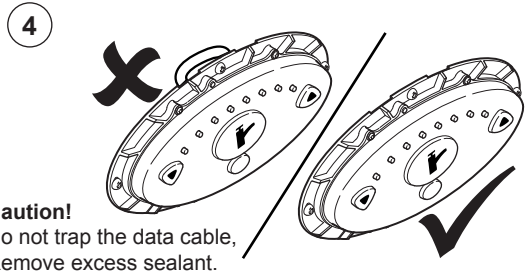
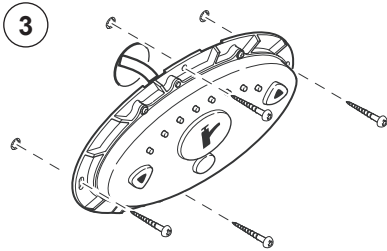

# Rada Sense (DMV)

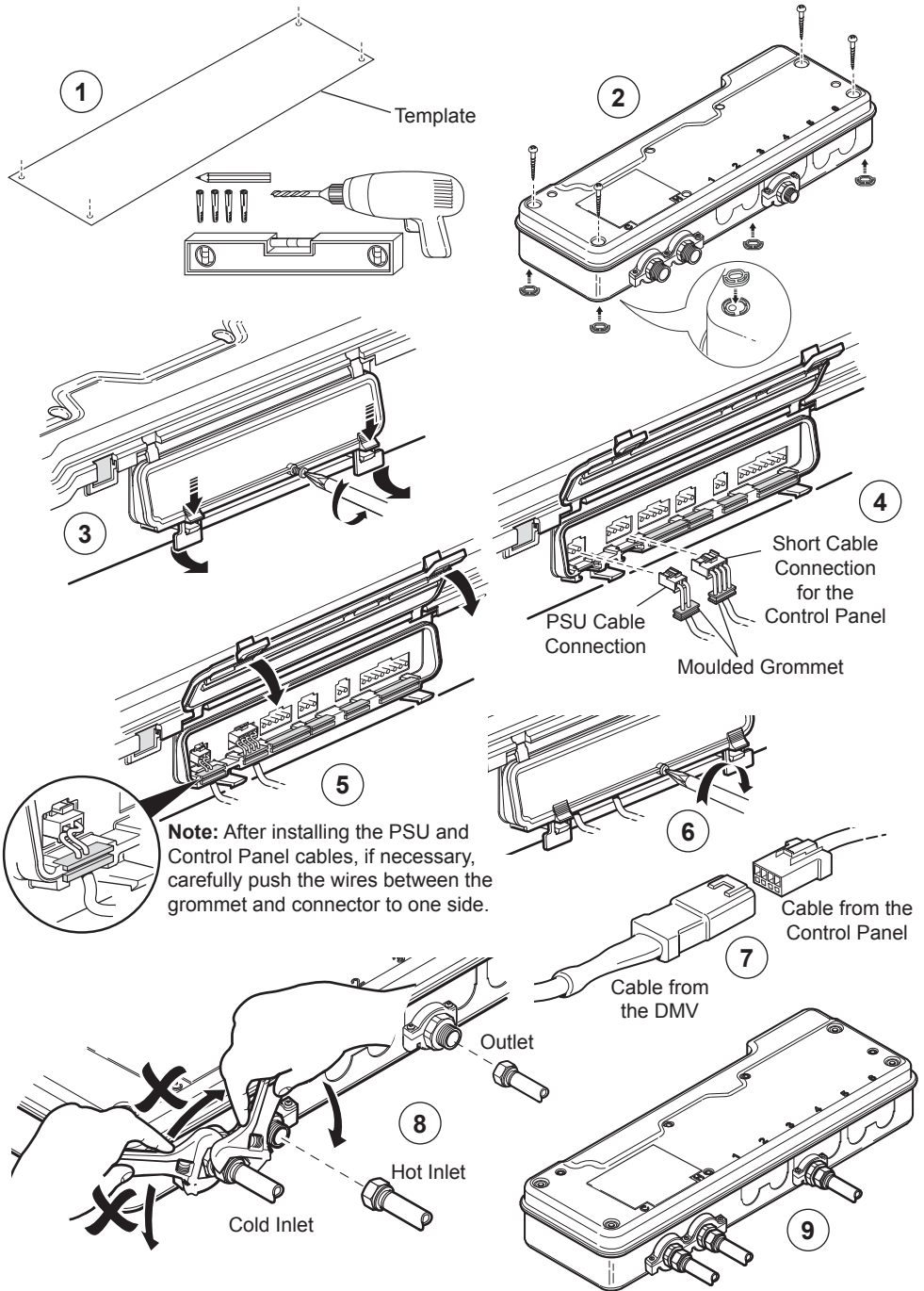

# OPERATION

Position your hand anywhere in front of the control panel to activate the DMV. Water is delivered at the default temperature, refer to '**SPECIFICATION**'.

**Note:** The sensors are designed to operate at a distance of up to 30 mm. There is no need for the user to touch the control panel.

Position your hand over the Down arrow to obtain a cooler mix. When only the blue light is illuminated on the control panel, then only cold water is being supplied. If the blue light is flashing, then the minimum preset temperature is being delivered.

Position your hand over the Up arrow to obtain a hotter mix.

**Note:** Adjusting the temperature automatically resets the flowtime.

The water should flow until either it is switched off manually (by positioning your hand over the central logo, 'Flow sensor') or the programmed flow time duration has elapsed.

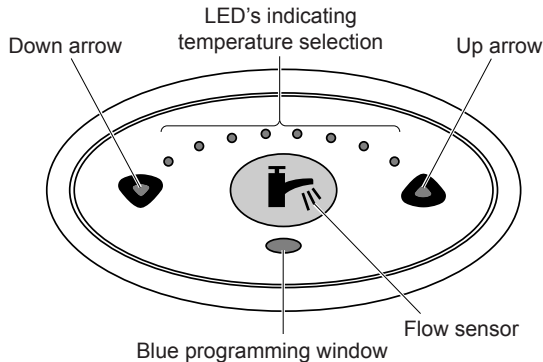

## Duty Flush (*Default DISABLED*)

The DMV incorporates an option for duty flush which can be selected with the aid of the Bluetooth Mobile App (available for Apple and Android), refer to the **Rada Sense App Guide (1411800-W2)**. If duty flush is selected and the DMV is not used for a period of time (pre-set waiting period) the standing water within the DMV will be flushed out.

Duty flush temperature, waiting period and flush period are preset at the factory. These settings can be reset, refer to the **Rada Sense App Guide (1411800-W2)**.

## Disinfection

The DMV incorporates an option for disinfection which can be selected with the aid of the Bluetooth Mobile App (available for Apple and Android). The default disinfection settings can be reset, refer to the **Rada Sense App Guide (1411800-W2)**.

# COMMISSIONING

Commissioning must be carried out in accordance with these instructions, and must be conducted by designated, qualified and competent personnel.

**Note: For Healthcare Installations, all results must be recorded.**

1. Restore the water supply and check that there are no leaks.
2. Restore the power supply.
3. Position your hand over the flow sensor (indicated by a tap) on the control panel to start the DMV, to flush out any air.
4. Check the supply temperatures and pressures are within the range stated in '**SPECIFICATION**' and the guidance information on the prevention of legionella.
5. For Type 3 installations, check that the designation of the DMV matches the application. The supply pressures and temperatures are within the permitted range for the application. Refer to '**SPECIFICATION**' and the **TMV3 Requirements Manual**.
6. Check inlet pipework temperatures for correct function of checkvalves i.e. the hot water does not cross flow into the cold water supply.
7. Check that the temperature(s) and flow rates obtainable are acceptable.
8. Carry out a performance check:

## Healthcare

Isolate the cold water supply to the mixing valve and monitor the mixed water temperature. Record the maximum temperature achieved and the final stabilised temperature on restoration of the cold water supply.

**Note:** The final stabilised mixed water temperature should not exceed the values shown below. Any higher temperatures should only occur briefly.

|           |       |
|-----------|-------|
| Bidet     | 40 °C |
| Washbasin | 43 °C |

## Commercial

Locate another outlet on the common cold water supply close to the mixing valve (operating this outlet should cause a drop in supply pressure), and note the subsequent effect on blend temperature (should be no more than 2 °C change).

## Maximum Temperature Setting

The maximum blend temperature obtainable by the user is limited to prevent accidental selection of a temperature that is too hot.

The DMV is fully performance tested and the maximum temperature is factory preset, refer to '**SPECIFICATION**'.

Provided that the installation conditions comply with the operating parameters given in '**SPECIFICATION**', the maximum temperature should not require adjustment. For Type 3 valves, the maximum blend temperature is determined by the application. Refer to the **TMV3 Requirements Manual**.

Should the user require to change the Default, Minimum, Maximum Temperatures or the Flow Times, refer to the **Rada Sense App Guide (1411800-W2)**.

**Caution!** The outlet temperature must be re-checked after a new temperature has been programmed.

### Programmable via Mobile App

A mobile app (iOS and Android) is required to adjust factory settings, retrieve data, configure duty flush and disinfection settings and perform disinfection routines using Low Energy Wireless Bluetooth® communication. Both versions of the app are commercially available free of charge via the relevant app stores and compatible with both phone and tablet devices. Please refer to the **Rada Sense App Guide (1411800-W2)** for further details.

# MAINTENANCE

## Planned Maintenance

Malfunction of Thermostatic Mixing Valves is almost always progressive in nature and will be detected by the use of proper temperature checking and maintenance routines.

Certain types of system can result in the valve having excessive 'dead-legs' of pipework, or auxiliary cold water supply added to the mixed water from the valve. Such systems can disguise the onset of thermostatic mixing valve malfunction and should not be used.

We recommend a preventative maintenance procedure based on site conditions and the risk to the user. All results must be recorded in a log book.

## Healthcare

Healthcare applications are hospitals, aged person facilities, residential care homes, etc. and any other applications where the user is similarly at risk.

Ultimately, the user or attendant must exercise diligence to make sure that the delivery of warm water is at a stable, safe temperature. This is particularly important in such procedures as supervised bathing where patients are unable to respond immediately to unsafe temperatures.

For Type 3 valves, refer to the **TMV3 Requirements Manual** for information and guidance on in-service testing.

## Commercial

Check for correct blend setting every 6 months.

Follow the TMV3 in-service test procedure every 12 months. Refer to the **TMV3 Requirements Manual**.

## Critical Components

Irrespective of supply and usage conditions or the evidence of in-service tests, critical components should be replaced at intervals of no more than 5 years.

| Pack Number | Description                  |
|-------------|------------------------------|
| 463.31      | DMV Solenoid manifold (Open) |
| 463.08      | Single Thermistor pack       |

**Note:** During the replacement of critical components, it may be necessary to replace other non-critical components.

## Cleaning

The Rada Sense Control Panel may be temporarily disabled for cleaning purposes. Place the magnetic key (supplied) over the programming window. This will disable the sensors for 30 minutes or until the magnetic key is reapplied.

External surfaces may be wiped clean with a soft cloth, and if necessary, a mild washing-up type detergent or soap solution can be used.

**Caution:** Plated or plastic fittings should only be cleaned using a mild washing up detergent or soap solution and wiped dry with a soft cloth.

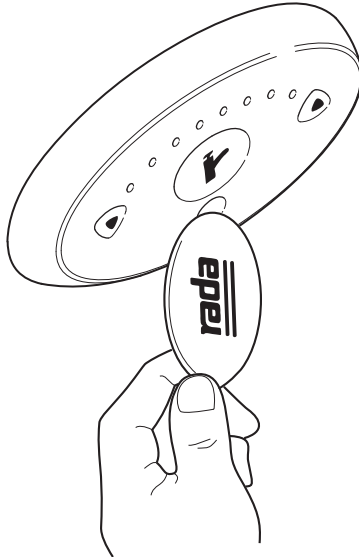



## Checkvalves and Filters

**Warning!** The DMV may contain hot water, so care must be taken when draining the valve of any residual water. Isolate the supplies to the DMV and operate the control panel to release pressure and to assist the draining of residual water.

**Note:** The DMV has checkvalve and filter packs (cartridge assemblies) or checkvalves and strainers fitted. These components can be removed for cleaning. Inlet strainers can be flushed through under a jet of water to remove any lodged particles.

**Caution!** The checkvalves are not serviceable items, so any apparent wear or damage will require their renewal.

**Note:** Make sure all components are clean before refitting the 'O' seals. To assist in refitting, lightly wipe the 'O' seals with a **silicone based lubricant**.

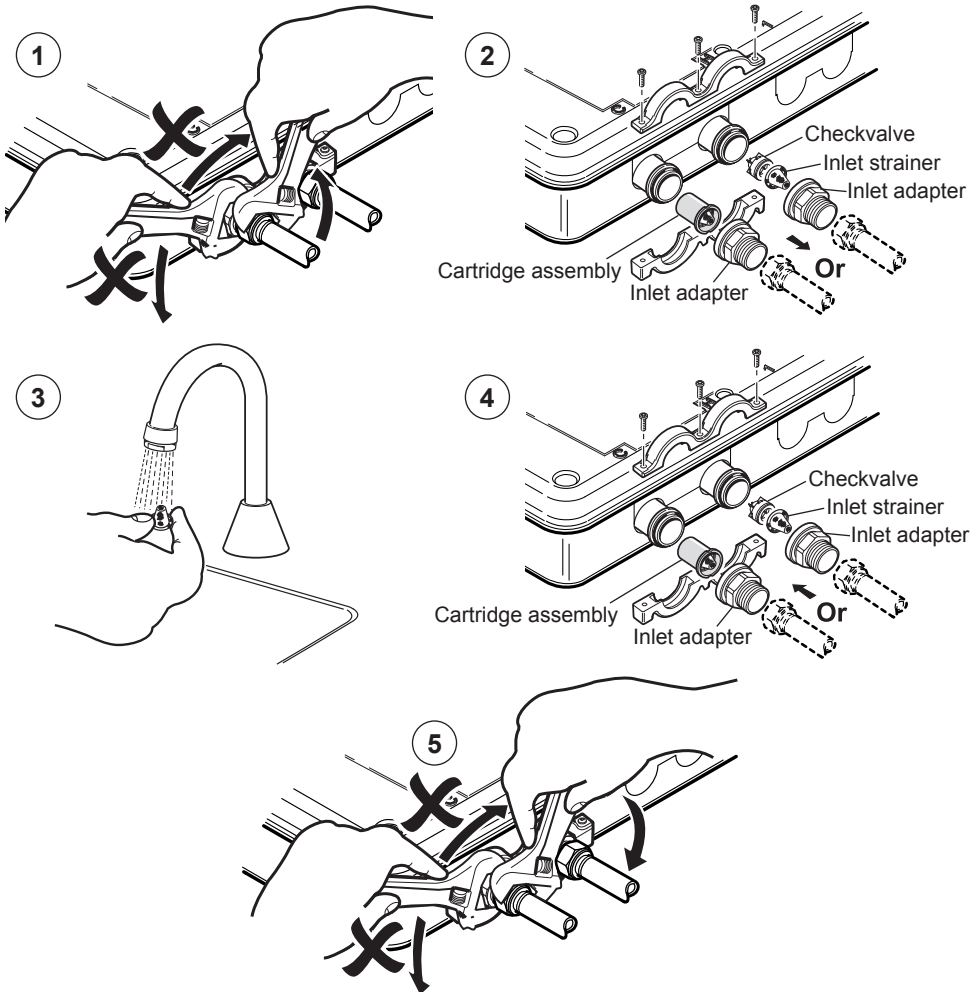

Restore the hot and cold water supplies. Check that there are no water leaks.

# FAULT DIAGNOSIS

Maintenance must be conducted by designated, qualified and competent personnel.

**Warning!** Isolate power supply and water supply when any maintenance work is carried out on the DMV.

The DMV may contain hot water, so care must be taken when draining the DMV of any residual water.

**Caution!** The inlet/outlet connections on the DMV, must be held tightly so that they do not move, when the connections are being loosened or tightened.

| <b>Symptom</b>   | <b>Cause/Rectification</b>   |
|--|--|
| <b>1.</b> Control Panel not illuminated.                     | <ul style="list-style-type: none"> <li>a. Check that you have the correct control panel or DMV for your application.</li> <li>b. Control panel has been disabled : enable the control panel with the magnetic key, refer to '<b>Cleaning</b>'.</li> <li>c. The mains electricity has been disabled : check and rectify.</li> <li>d. The power supply unit has been disabled : check the fuse and connections.</li> <li>e. Electrical connections to/from the DMV have been disturbed : make sure the connections are secure.</li> <li>f. Memory requires resetting : switch the power supply to the DMV, OFF and then ON.</li> </ul> |
| <b>2.</b> Only cold water from outlet.                       | <ul style="list-style-type: none"> <li>a. No hot water reaching mixing valve : check and rectify.</li> <li>b. The hot water inlet may be blocked : check strainer for any blockage.</li> <li>c. Installation conditions are outside the operating parameters : refer to '<b>SPECIFICATION</b>'.</li> <li>d. Hot and cold feeds connected to the wrong inlets : rectify.</li> </ul>   |
| <b>3.</b> Continuous flow.                                   | <ul style="list-style-type: none"> <li>a. System switches itself on and off.</li> <li>b. System will not switch off : isolate power supply/ water supply and contact your Local Agent/ Customer Care.</li> </ul>   |
| <b>4.</b> Hot water entering the cold supply, or vice versa. | <ul style="list-style-type: none"> <li>a. Remove and clean the checkvalve cartridges. Renew as necessary.</li> </ul>   |



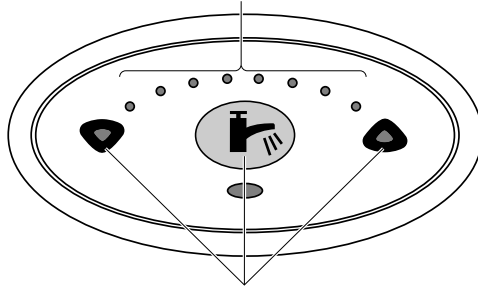

| <b>Symptom</b>   | <b>Cause/Rectification</b>   |
|--|--|
| <p><b>5.</b> Fluctuating or reduced flow rate. Normal function of mixing valve when operating conditions are unsatisfactory.</p> | <p>a. The inlet/outlet fittings may be restricted: check the inlet/outlet strainers, refer to <b>'MAINTENANCE'</b>.</p> <p>b. The water outlet pressure is low: check the flow rate is above the stated minimum, refer to <b>'SPECIFICATION'</b>.</p> <p>c. Fluctuating flow: make sure that dynamic inlet pressures are within specification, refer to <b>'SPECIFICATION'</b>.</p> <p>d. Fluctuating water temperature: make sure that inlet temperature differentials are sufficient, refer to <b>'SPECIFICATION'</b>.</p> |
| <p><b>6.</b> Blend temperature drift or temperature cycling.</p>   | <p>a. Refer to symptoms <b>4</b> and <b>5</b>.</p> <p>b. Hot water supply temperature fluctuation : check and rectify.</p>   |
| <p><b>7.</b> Maximum blend temperature setting too hot or too cool.</p>  | <p>a. Incorrect maximum temperature setting : refer to <b>'COMMISSIONING'</b>.</p>   |
| <p><b>8.</b> Water leaking from the DMV.</p>   | <p><b>Warning! Isolate mains electricity and water supply.</b></p> <p>a. Check that the connections are secure.</p> <p>b. Seal(s) worn or damaged on the inlet/outlet connections : obtain service pack and renew all seals.</p> <p>c. Internal leakage : unit requires overhaul.</p>  |
| <p><b>9.</b> LED's are flashing on the control panel and the DMV will not activate.</p>  | <p>a. An error has been diagnosed, refer to <b>'Self-diagnostic Errors'</b> (following table).</p>   |
| <p><b>10.</b> The DMV keeps switching OFF before the completion of the programmed time flow period.</p>                          | <p>a. Blend temperature too hot : Reset the DMV by switching the power supply to the DMV OFF, then ON.</p> <p>b. Make sure that the inlet temperatures are within specification, refer to <b>'SPECIFICATION'</b>.<br/>If the fault has not been rectified, contact your Local Agent or Customer Care.</p>  |

# Self-Diagnostic Errors

Error code is displayed by a combination of lit LED's

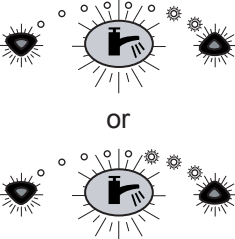

All three LED's flash at the same time

| Symptom   | Cause/Rectification  |
|---|--|
|    | <p>The Control Panel and the DMV are not compatible.</p> <p>a. DMV W or B requires CP W: check and rectify.</p> <p>If the symptom has not been rectified, contact your Local Service Engineer or Agent.</p>  |
|  <p style="text-align: center;">or</p>  | <p>Outlet Temperature is too high or Thermistor fault.</p> <p>a. The inlet/outlet fittings may be blocked: check the inlet/outlet strainers</p> <p>b. Cold water supply failure: reinstate supply</p> <p>c. Safety circuit may require resetting: enable the control panel with the magnetic key to reset.</p> <p>If the symptom has not been rectified, contact your Local Service Engineer or Agent.</p> |
|   | <p>Thermistor fault.</p> <p>Contact your Local Service Engineer or Agent.</p>  |
|    | <p>The Stepper Motor is stuck, the motor belt is broken or the Mixer assembly is jammed.</p> <p>Contact your Local Service Engineer or Agent.</p>  |
|    | <p>The Mixer assembly is jammed or very stiff.</p> <p>Contact your Local Service Engineer or Agent.</p>  |
| <p>Any other combinations.</p>  | <p>A fault has occurred on the Control PCB.</p> <p>a. Memory may require resetting: switch the power supply to the PSU, OFF then ON.</p> <p>If the symptom has not been rectified, contact your Local Service Engineer or Agent.</p>   |

# SPARE PARTS

**Note:** If fixing screws, grommets, 'O' rings or seals are disturbed, these parts will be included with the spare part.

- 463.01**    **C2 Valve Assembly** - *Includes Stepper Motor, Stepper Loom, Checkvalve and Filter Pack, Inlet Saddle Clamps and Thermistor Clip*
- 463.05**    **Seal Screw Pack** - *Components Identified 'A'*
- 463.06**    **Cable Cover Pack**
- 463.08**    **Single Thermistor Pack**
- 463.09**    **Inlet Adapters 1/2 BSP** - *x2 Adapters and Inlet Saddle Clamps*
- 463.17**    **Outlet Adapter 1/2 BSP** - *x1 Adapter and Outlet Saddle Clamps*
- 463.25**    **Checkvalve and Filter Pack (Cartridge Assembly)**
- 463.26**    **Blanking Plate Pack**
- 463.28**    **Internal Saddle Clamp**
- 463.31**    **Solenoid Manifold (Open)** - *Includes Manifold Cap and Internal Saddle Clamps*
- 463.36**    **Control PCB RADA C2/C4 Basin** - *Programmed with Basin Software*
- 463.41**    **Control PCB RADA C2/C4 Bidet** - *Programmed with Bidet Software*
- 463.43**    **Wiring Loom W/S/B/HP**
- 1653.155** **Rada Sense Washbasin/Bidet Control Panel**
- 463.77**    **Rada Sense Panel Cover 3 Sense (Chrome)**
- 463.83**    **12 V DC 45 W Power Supply Unit (PSU)**
- 463.84**    **Rada Sense Disable Key** - *x4*
- 463.93**    **Stepper Motor Loom**
- 464.03**    **Outlet Saddle Clamps**
- 464.04**    **Inlet Saddle Clamps**
- 464.29**    **Suppression Ferrite**
- 1621.195** **Timing Belt** - *x5*

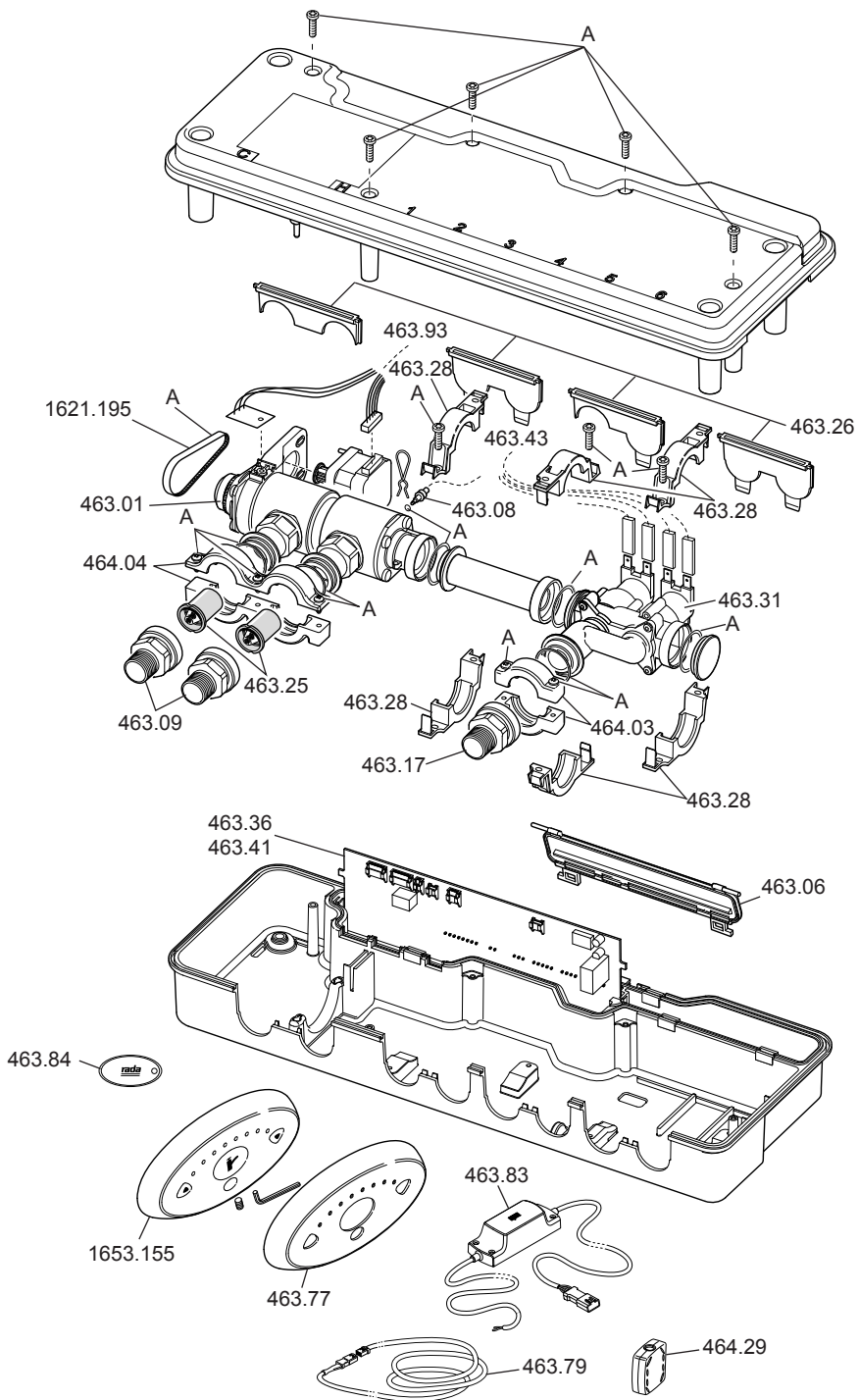

# ACCESSORIES

**463.79**    **Extension Lead - 3 m**

**Spouts**    Rada has a comprehensive range of spouts and shower fittings, available separately.

# CUSTOMER SERVICE

Your product has the benefit of our manufacturer's guarantee which commences from date of purchase or from the date of commissioning when product commissioning has been conducted within the UK by the Rada Commercial Field Service Team.

Outside of the UK please contact your local agent for all guarantee terms and conditions or visit [www.radacontrols.com](http://www.radacontrols.com) for further information.

**For UK (only) Customer Service & Post Installation enquiries**, including details of the Rada Commissioning, Responsive and Maintenance Contract Service Packages please contact:



**0344 571 1777**



**01242 282595**



**radacustomerservices@mirashowers.com**



**www.radacontrols.com**



Rada Controls, Cromwell Road, Cheltenham,  
Gloucestershire GL52 5EP

**For UK (only) Pre-Specification Enquiries** please contact:



**0344 571 1777**



**01242 282595**



**rada\_technical@mirashowers.com**



**www.radacontrols.com**



Rada Controls, Cromwell Road, Cheltenham,  
Gloucestershire GL52 5EP

**For Eire Only**



**01 531 9337**



**CustomerServiceEire@mirashowers.com**

*Rada is a registered trade mark of Kohler  
Mira Limited.*

*The company reserves the right to alter  
product specifications without notice.*



**rada**