



## Installatiehandleiding Rada Tec M1000 douchepaneel



**Rada Tec M1000**

**Bestelnr.: 3050111 (geborsteld rvs)**

**Bestelnr.: 1605332 (wit gecoat)**

# VARIANTEN

**VARIANT 1**

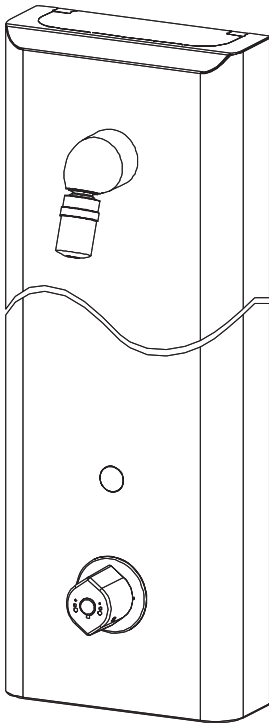

**VARIANT 2**

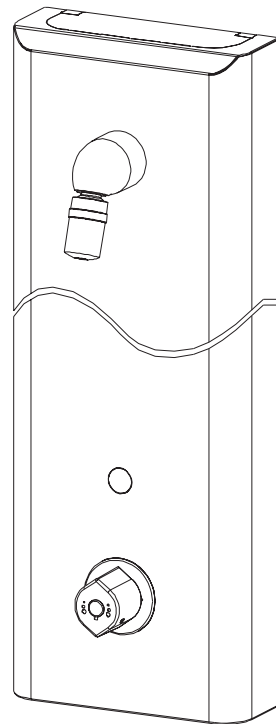

**VARIANT 1 (batterij)**

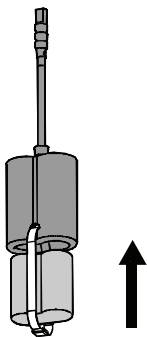

**VARIANT 2 (netadapter)**

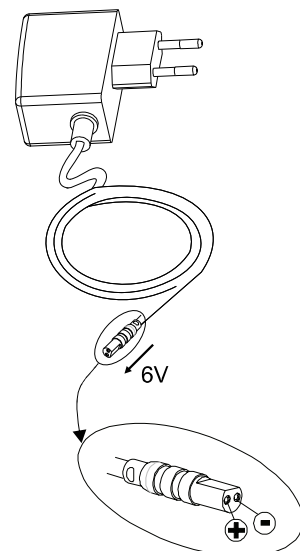

# 1. Technische Gegevens

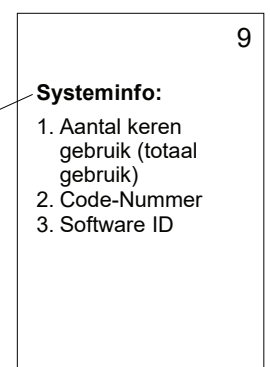
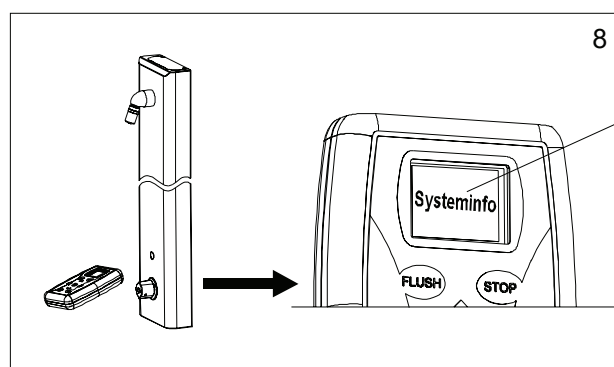
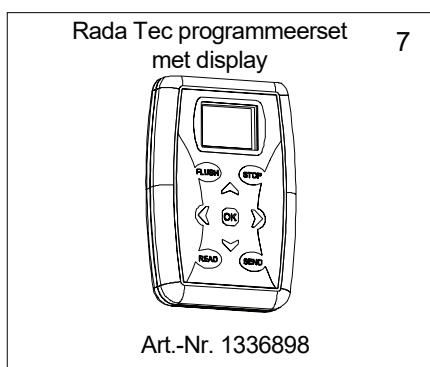
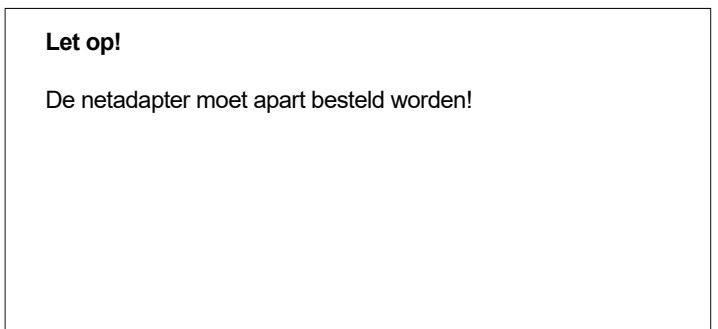
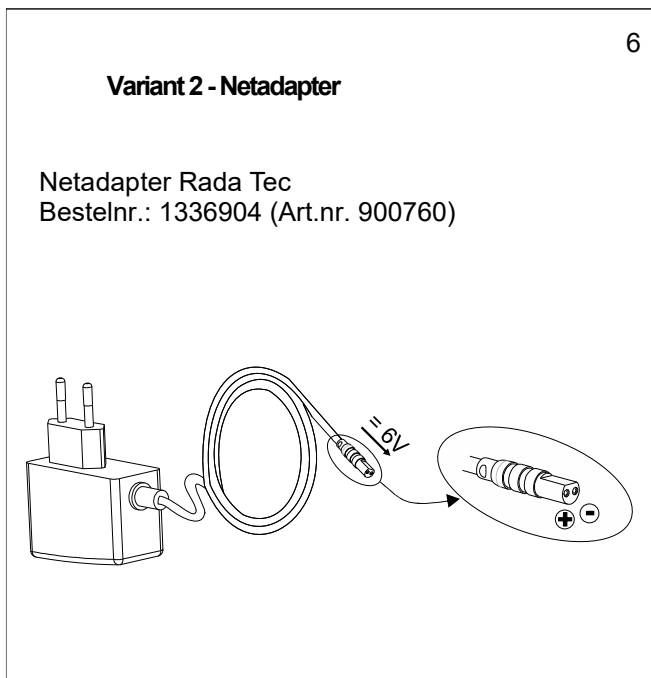
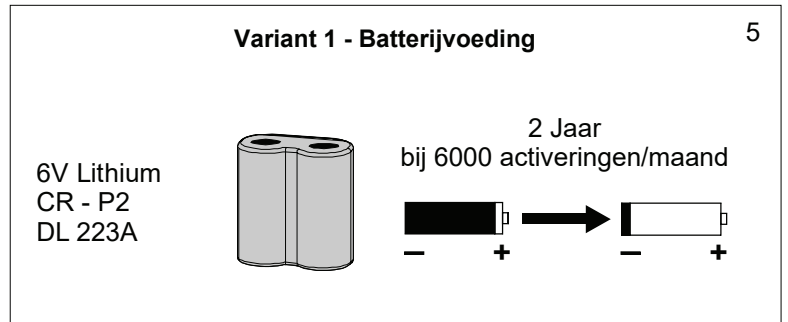
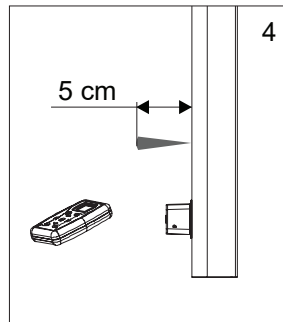
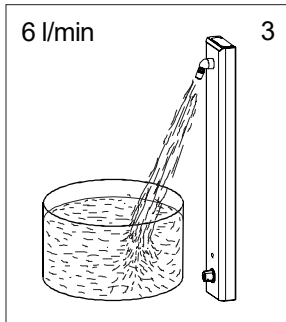
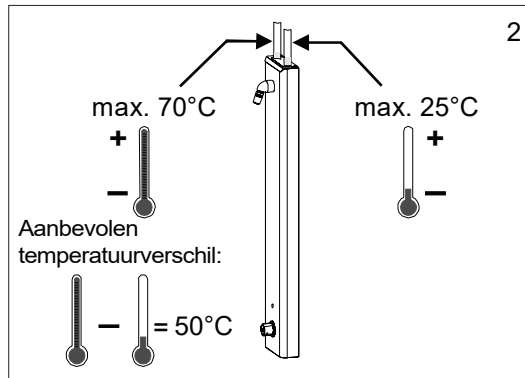
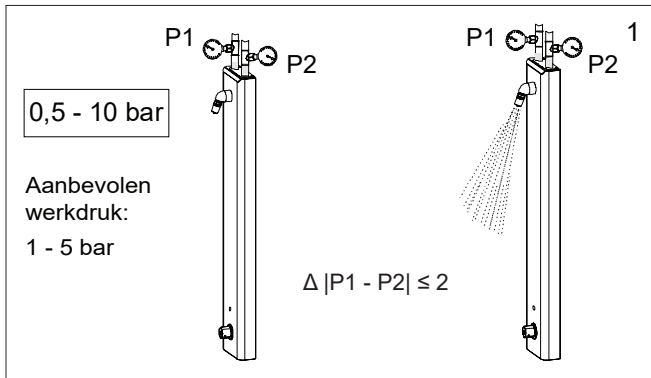

## 2. Functiebeschrijving

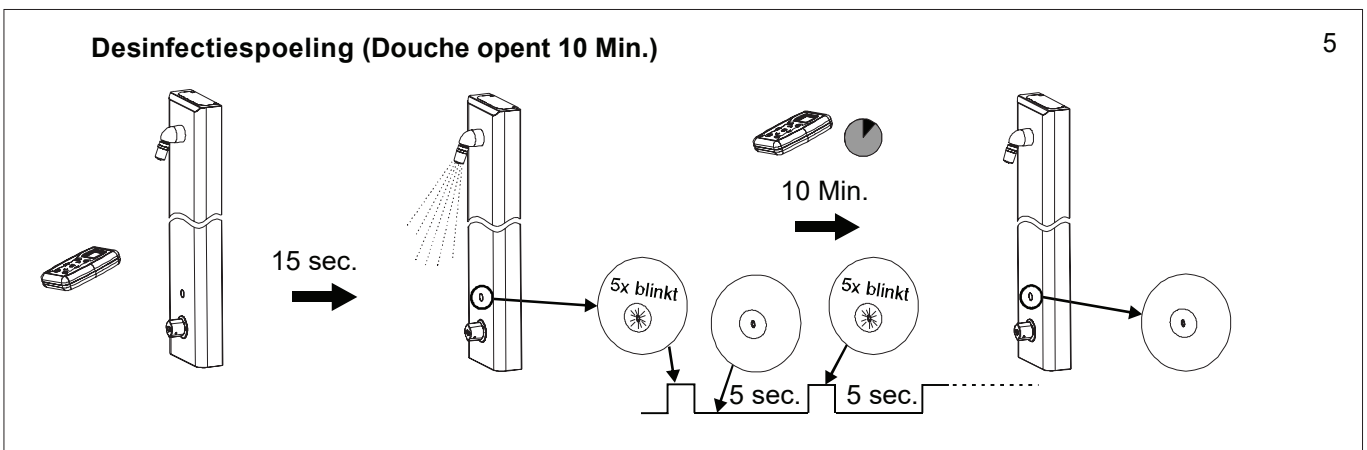
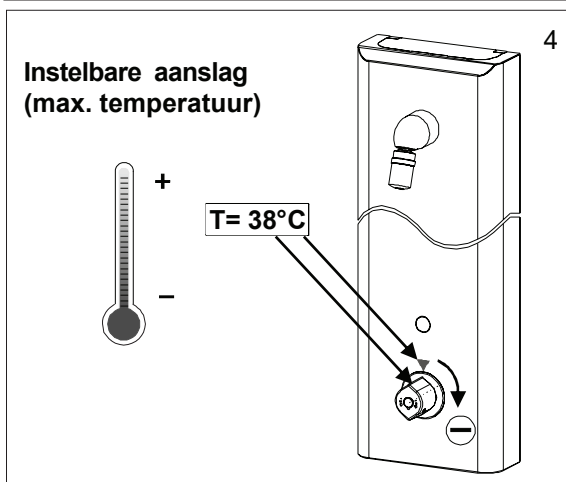
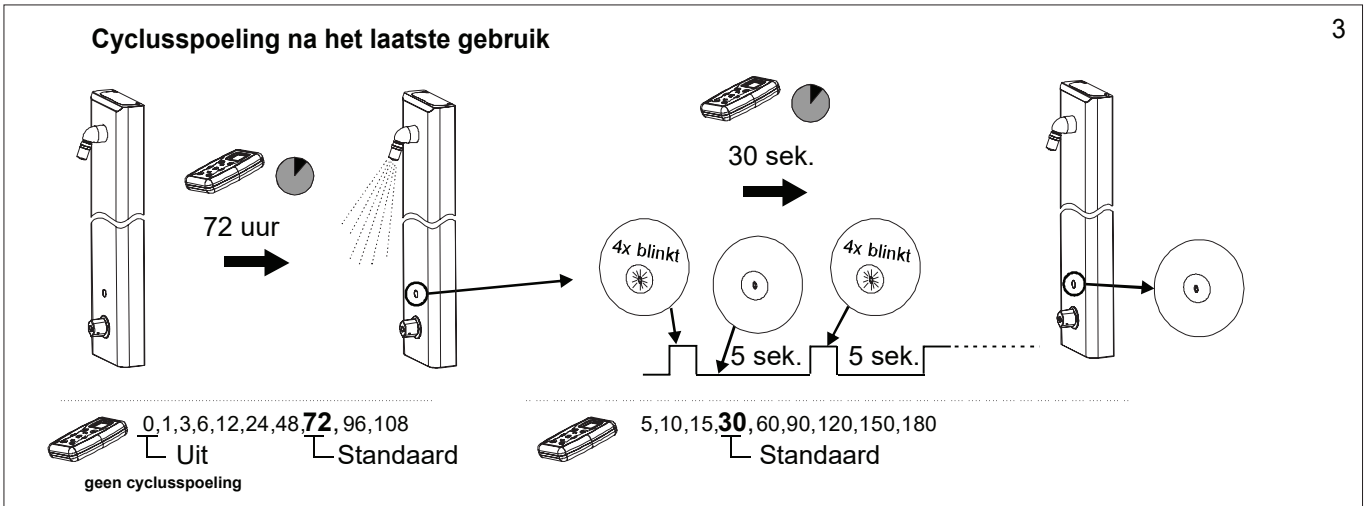
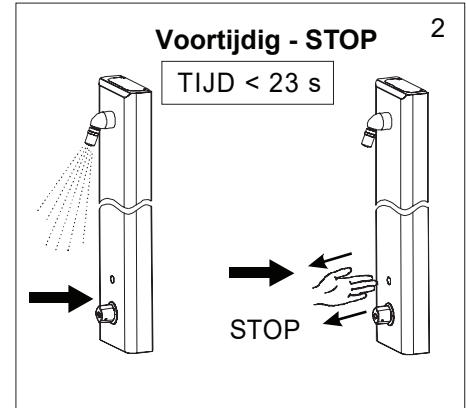
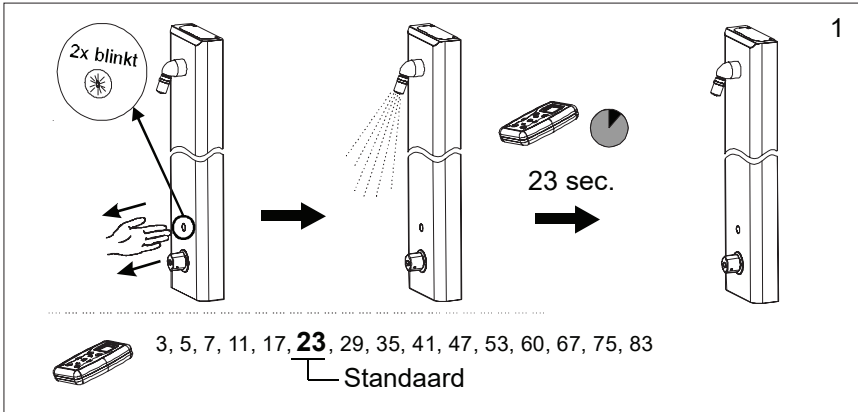

### STOP-Functie (schoonmaken)

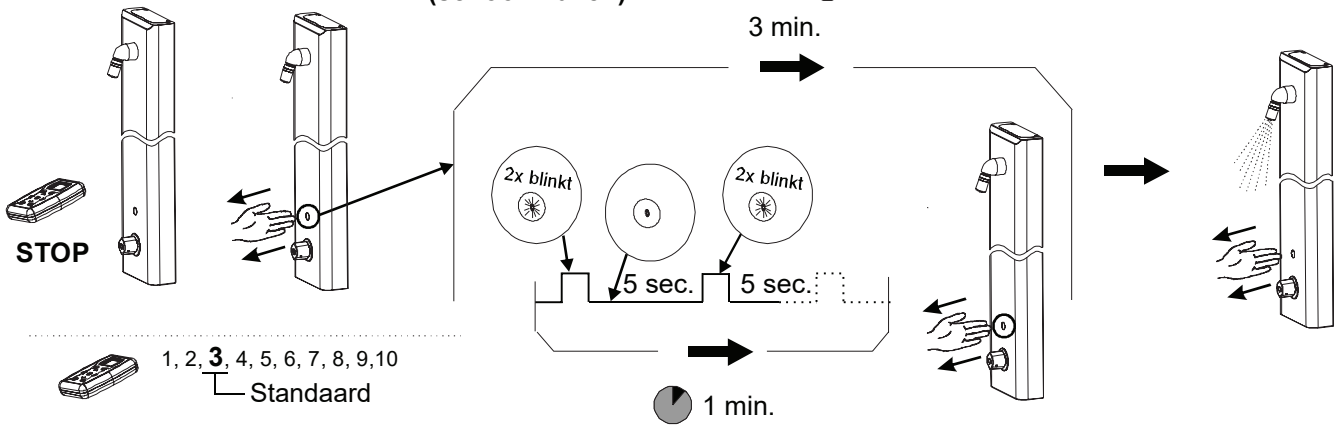

### Cyclusspoeling via extern contact

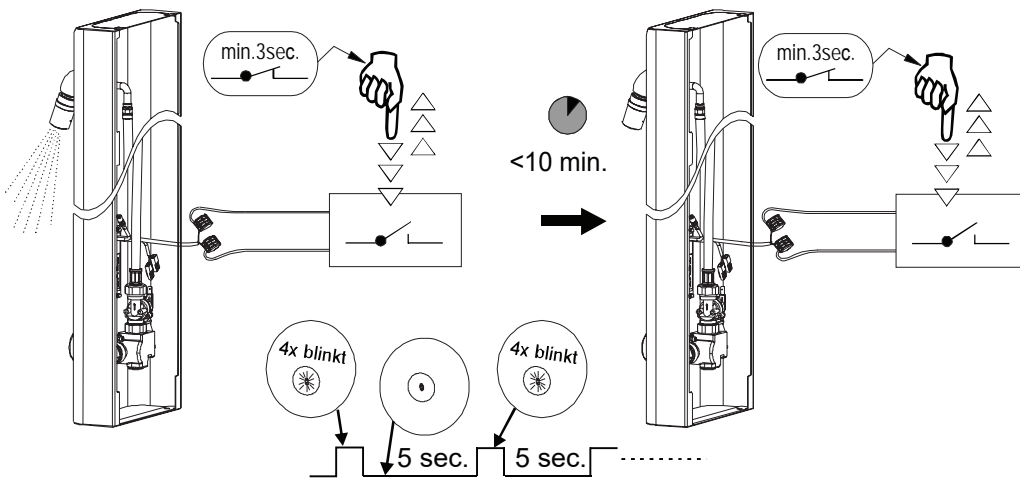
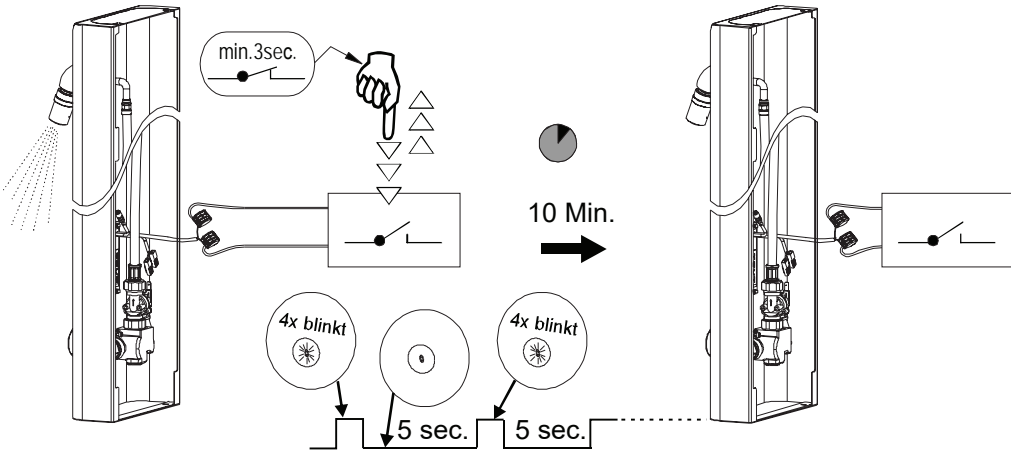

### 3.1 Maatschets - Watertoevoer uit de wand

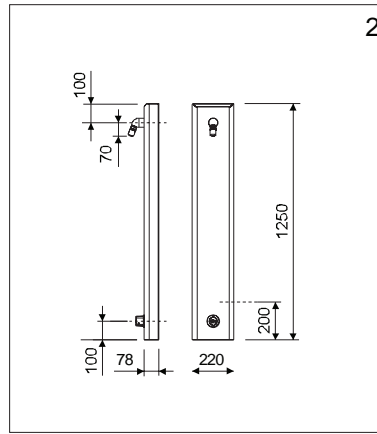
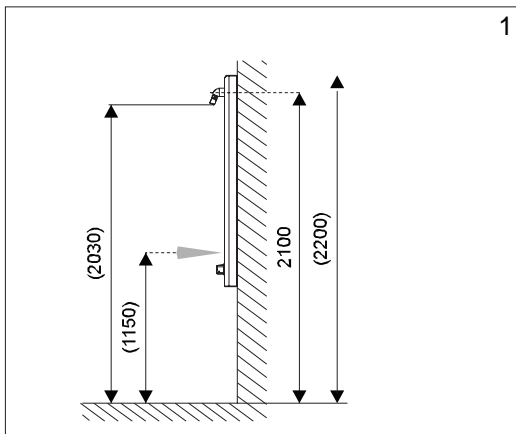

### 4.1 Installatievoorbereiding - Watertoevoer uit de wand

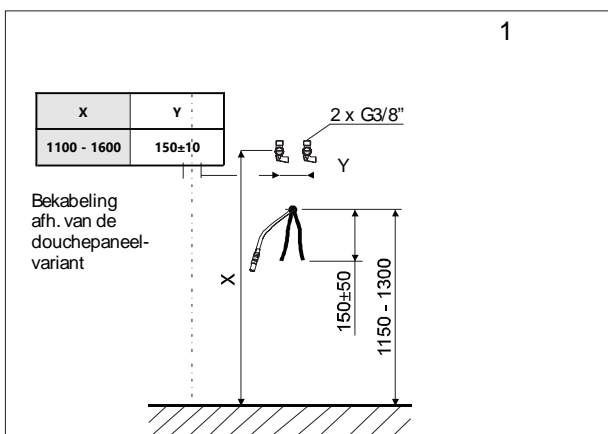

**Let op, extra benodigd:**

2 x Bestelnr.: 3050122 Aansluitset voor achteraansluiting (watertoevoer uit de wand)

### 5.1 Installatie - Watertoevoer uit de wand

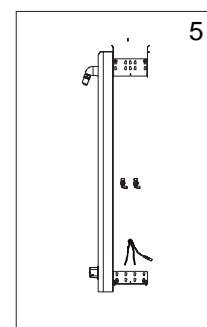
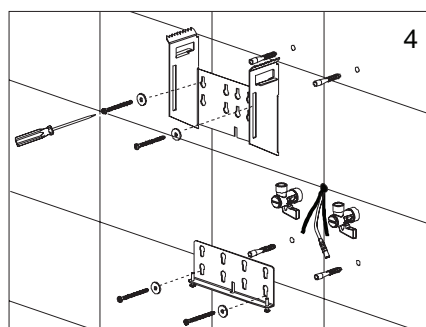
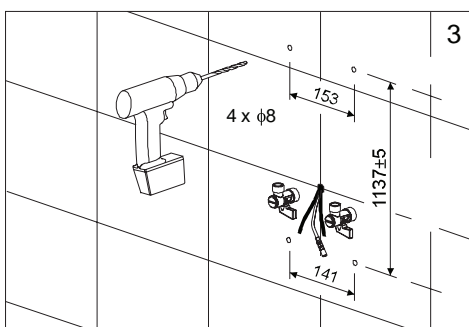
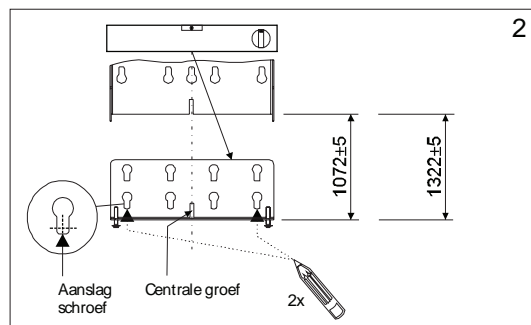
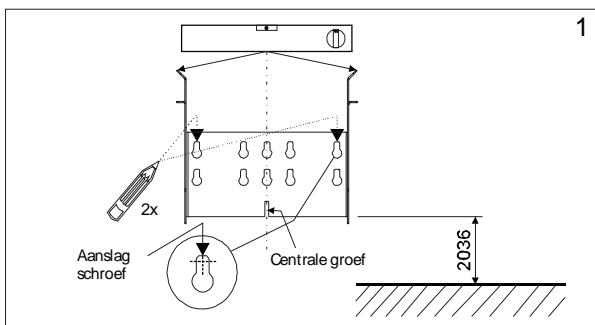

VARIANT 1 (batterij)

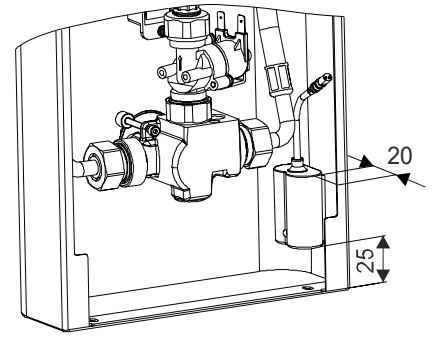
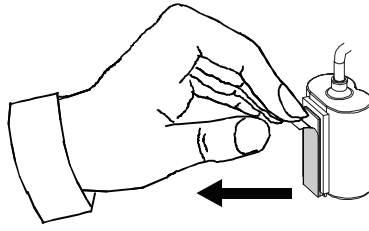
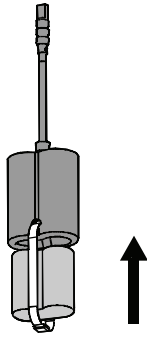

6.1

VARIANT 2 (netadapter) 6.2

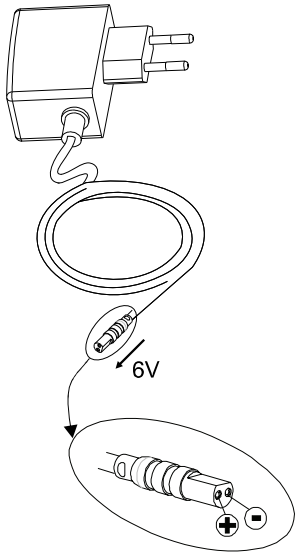

Kabels aansluiten 7

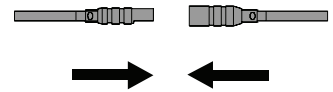
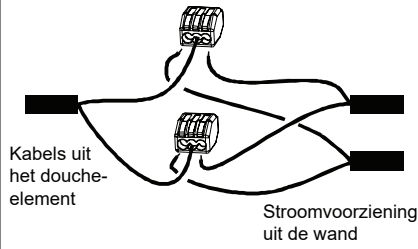

8

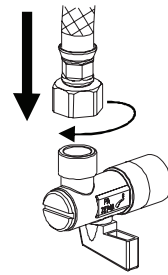

9

Open

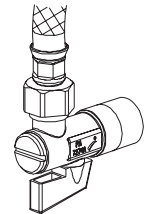

10

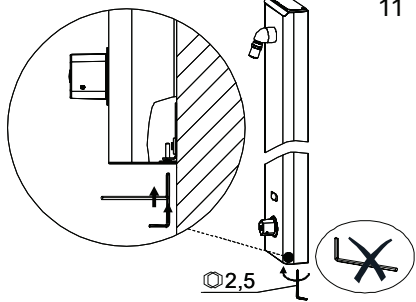

11

TEST

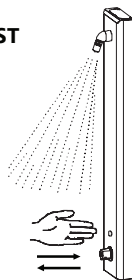

12

## 3.2 Maatschets - Watertoevoer van boven

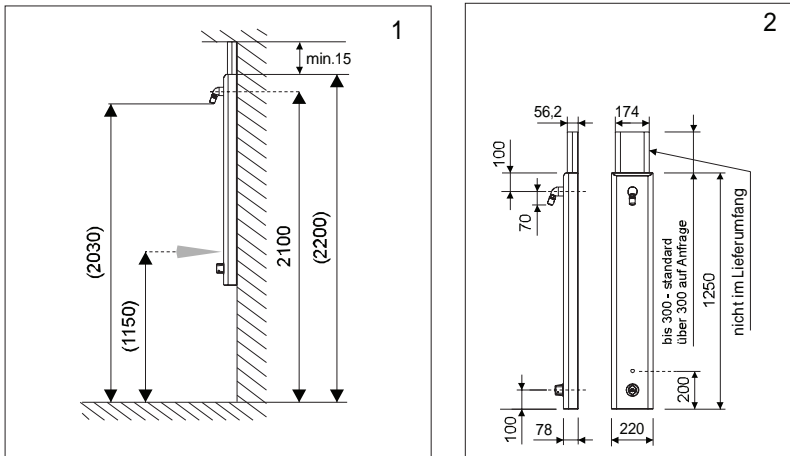

## 4.2 Installatievoorbereiding - Watertoevoer van boven

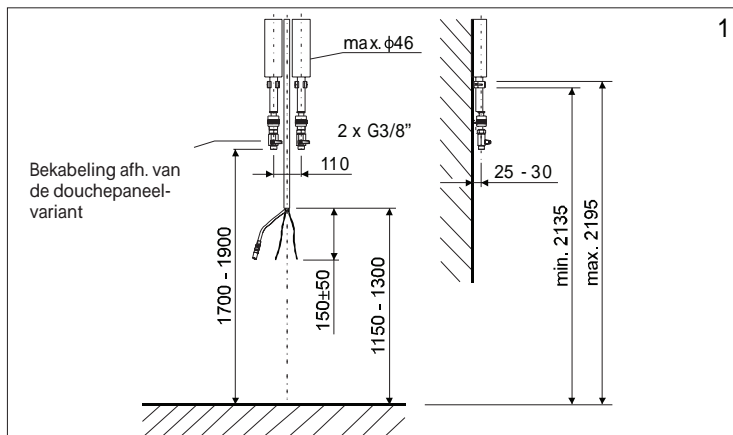

**Let op, extra benodigd:**

2 x Bestelnr.: 3050121 Aansluitset voor bovenaansluiting (watertoevoer van boven)

## 5.2 Installatie - Watertoevoer van boven

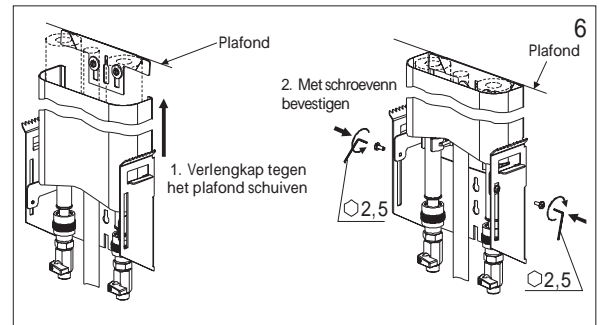
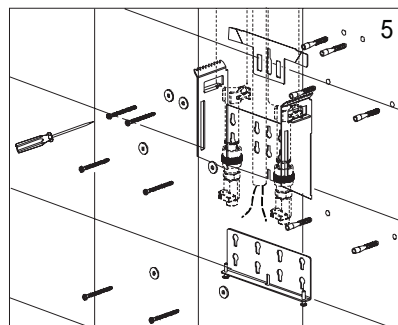
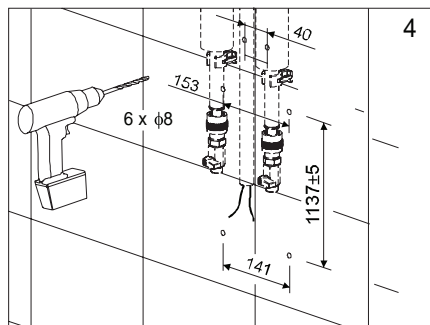
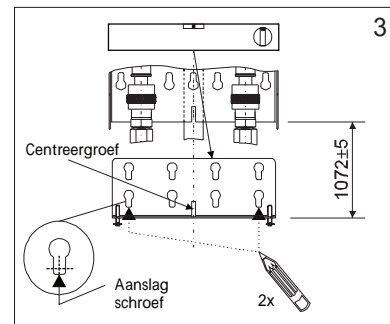
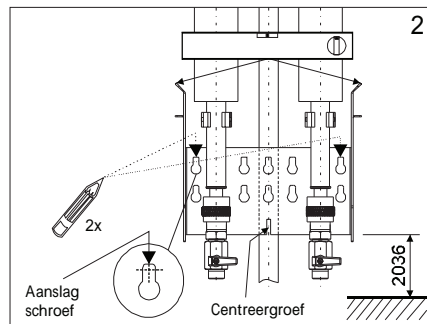
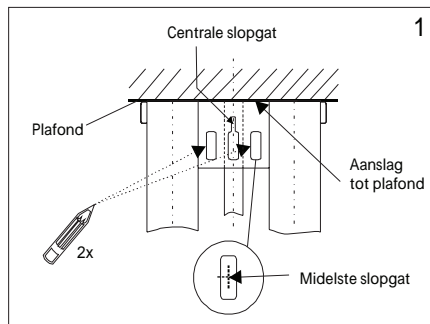



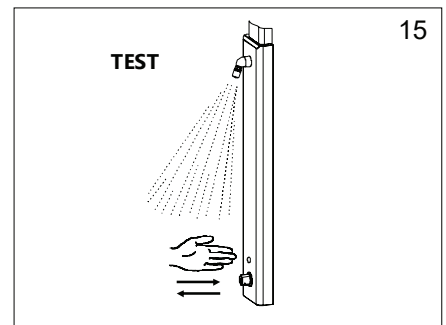
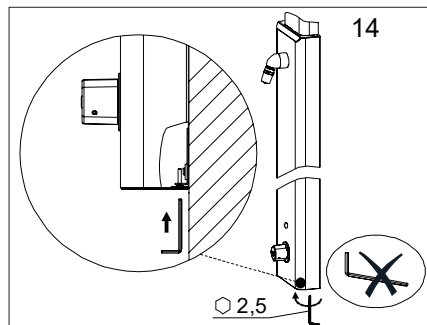
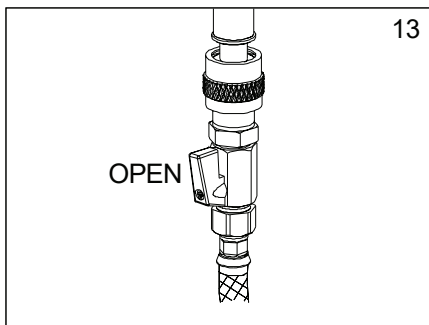
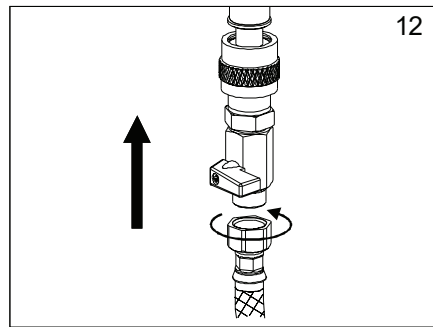
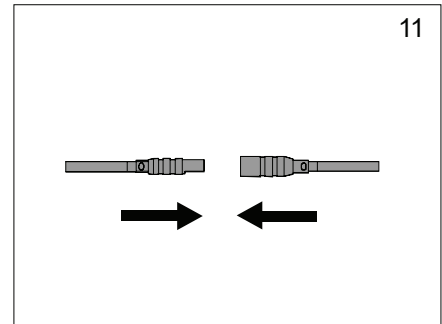
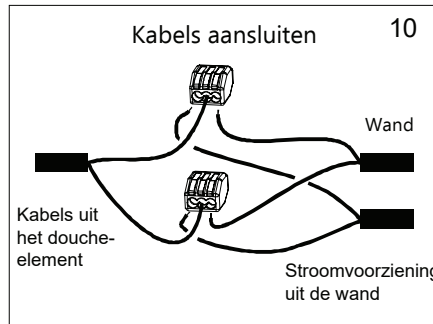
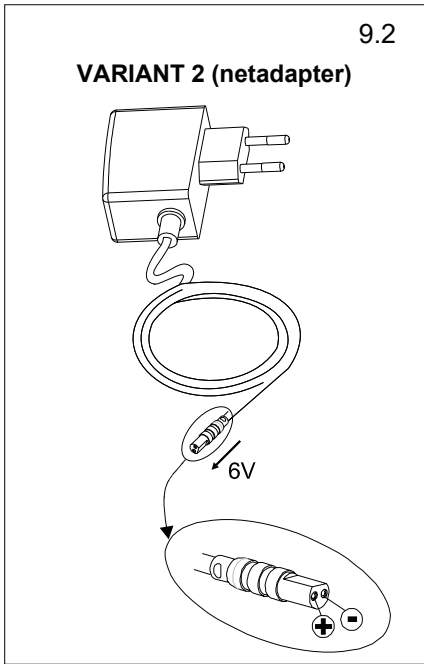
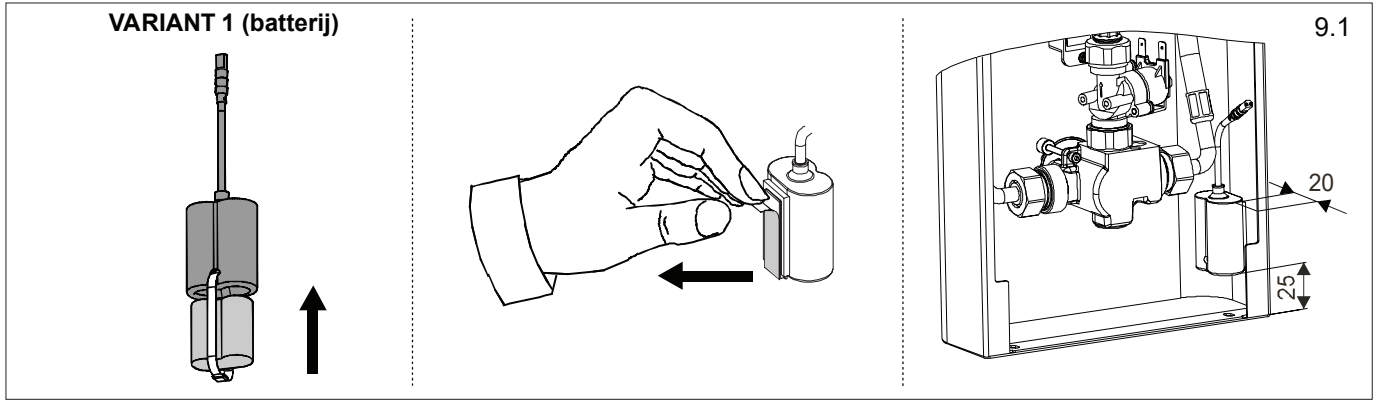
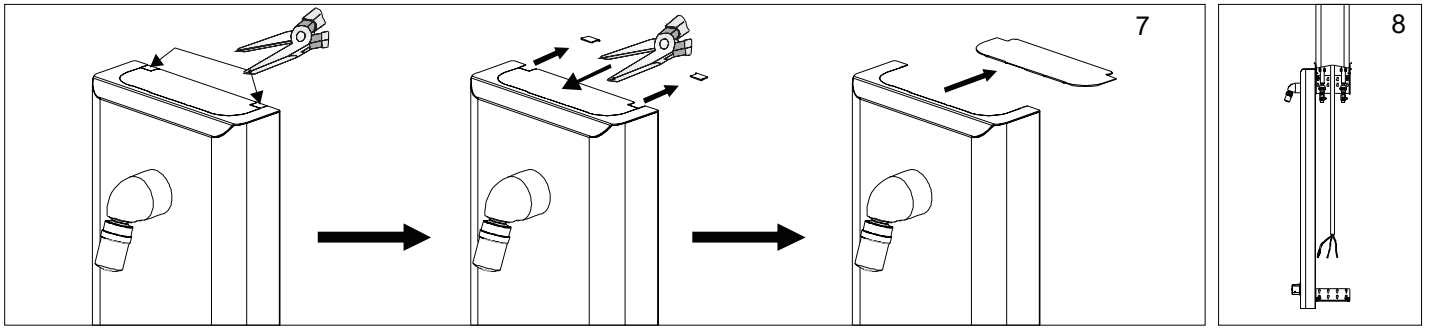

## 6. Batterij vervangen

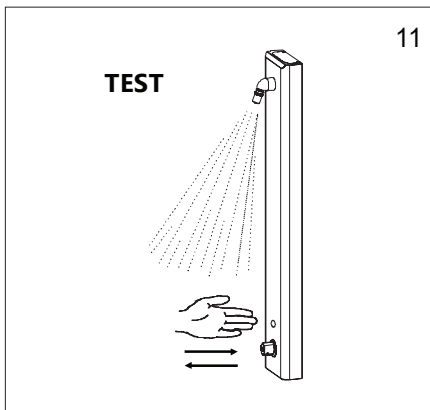
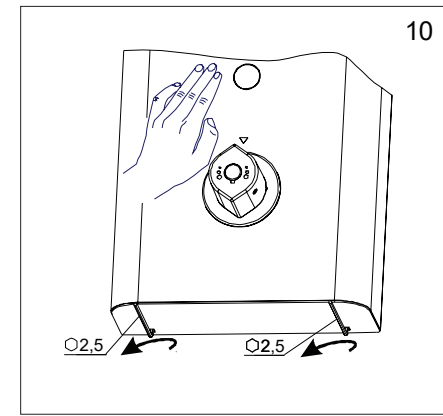
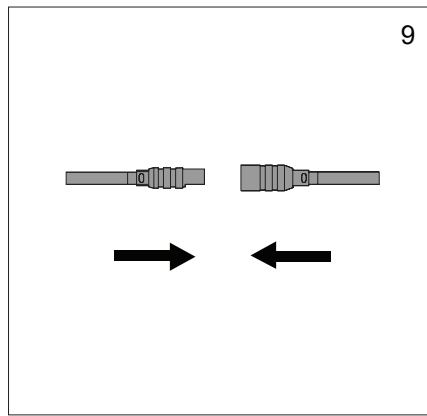
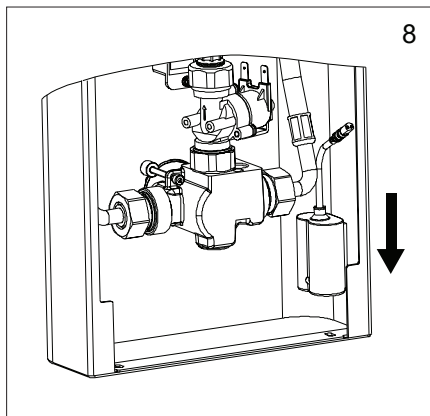
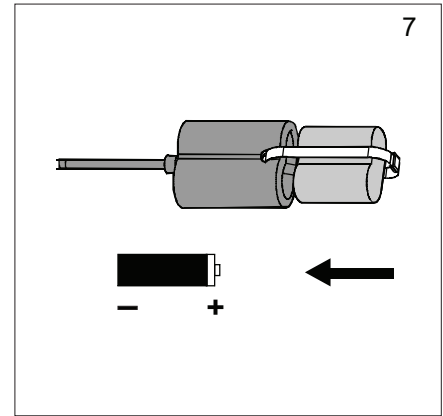
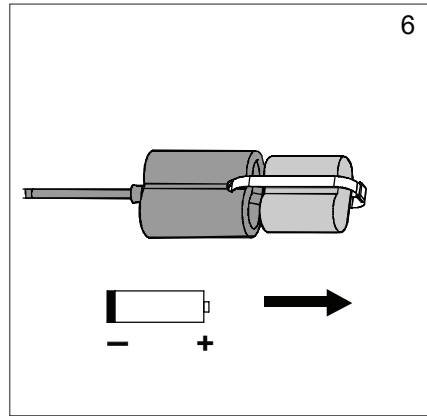
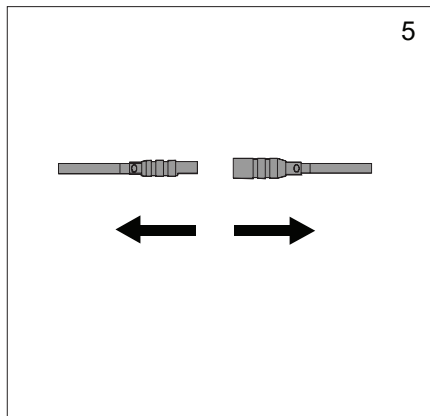
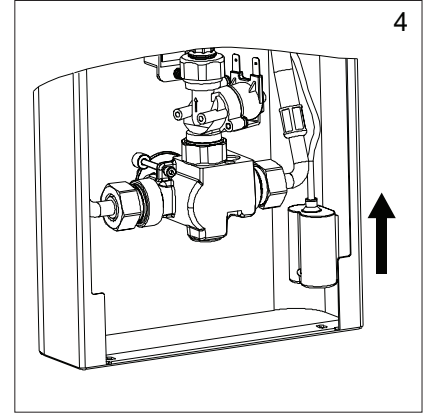
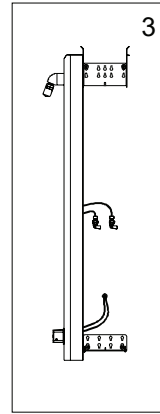
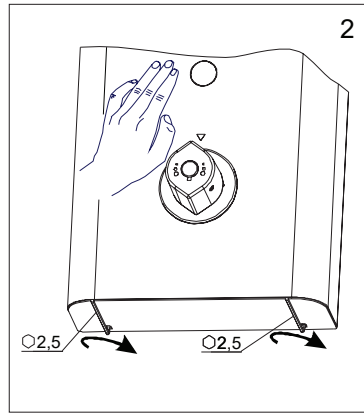
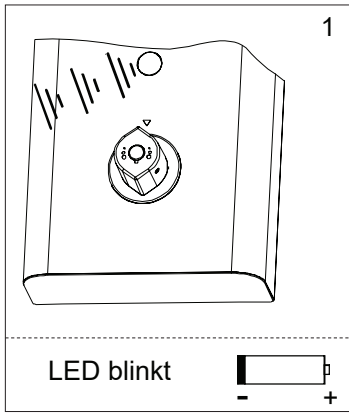

## 7. Zeefilters reinigen

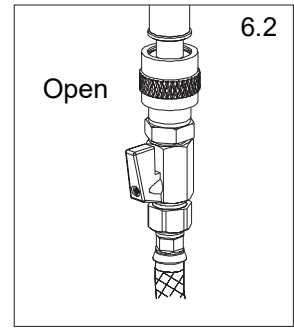
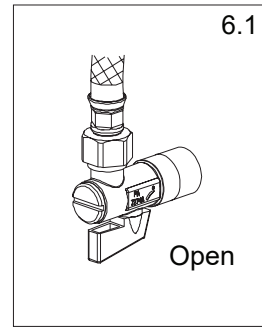
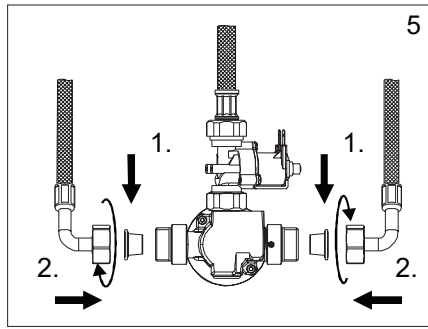
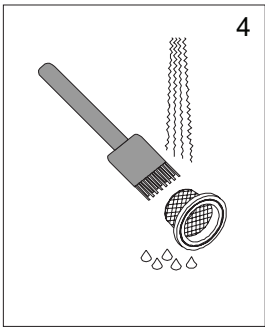
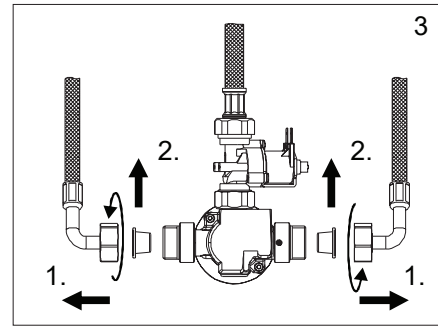
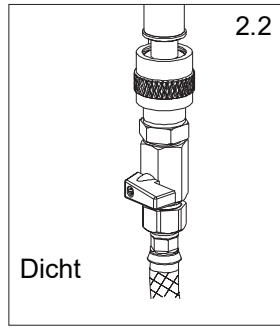
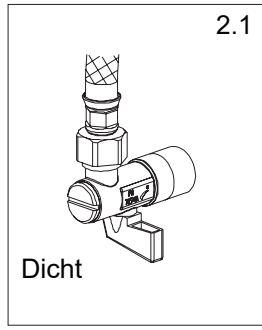
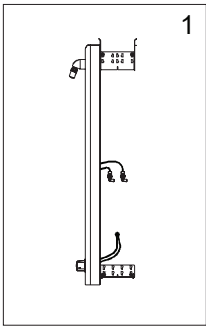

## 8. Thermische Desinfectie

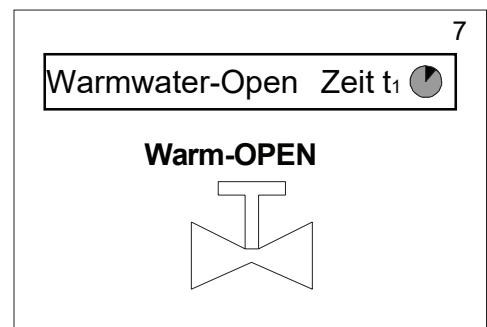
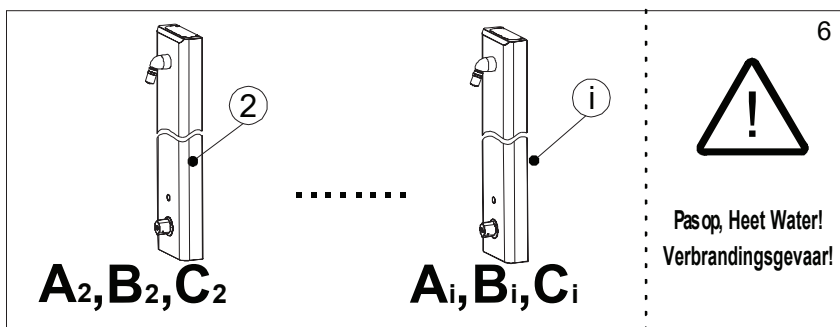
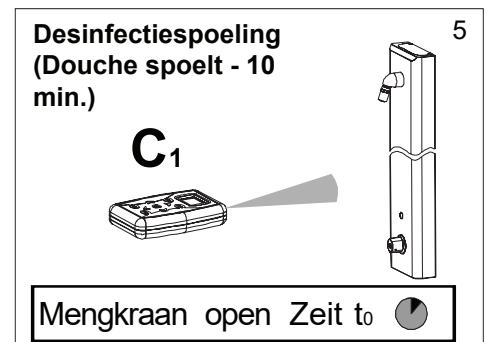
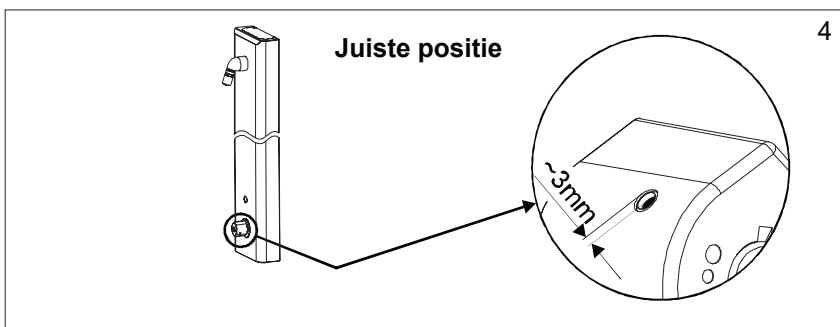
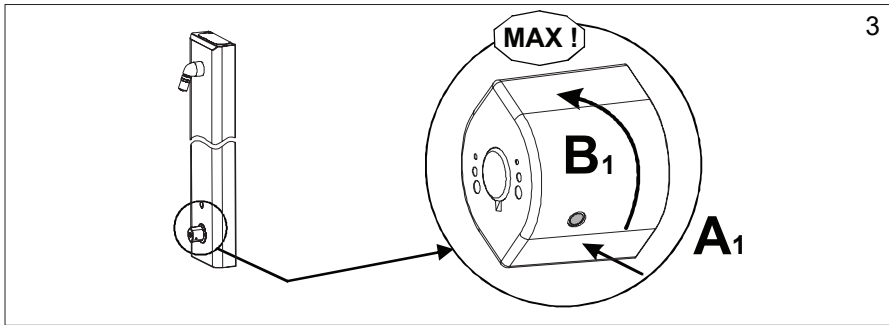
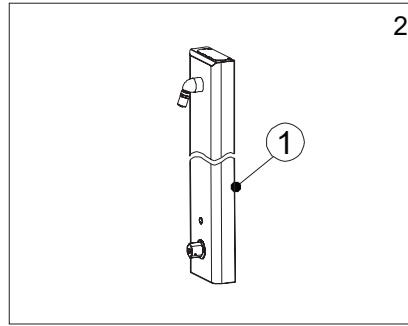
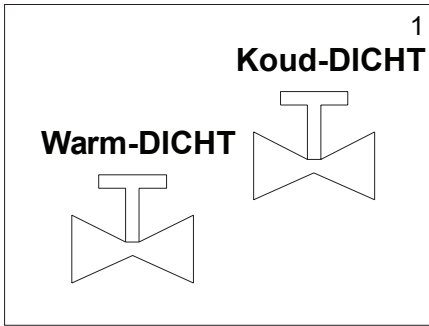

### Voorbeeld:

t<sub>0</sub> = 8.04 Uur

t<sub>1</sub> = 8.07 Uur

**t = 10 - (t<sub>1</sub> - t<sub>0</sub>)**

t = 10 - (8.07 Uur - 8.04 Uur) = 7 Min.



Minimale Watertemperatuur 68°C

**Desinfectietijd (vlgs richtlijnen)**

**10 - (t<sub>1</sub> - t<sub>0</sub>) = t**

Temperatuur T (°C)	Tijd t (Min.)
70	5
69	5,6
68	6,4
67	7,4
66	8,6
65	10

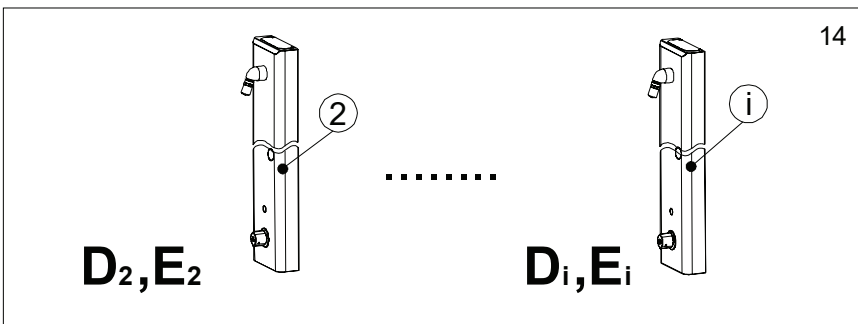
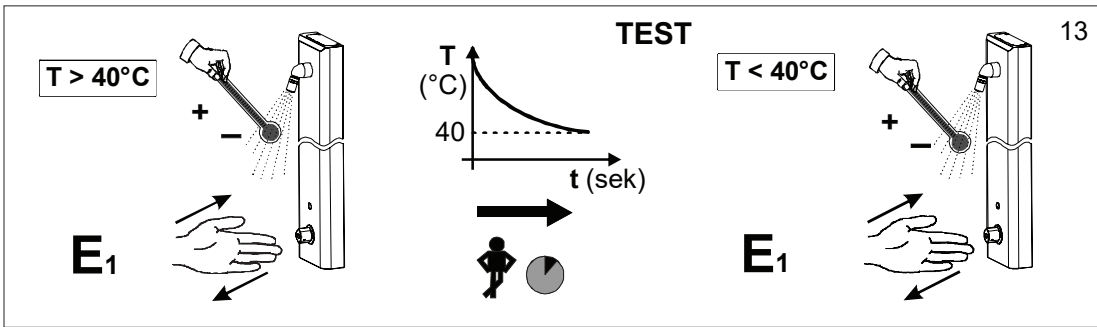
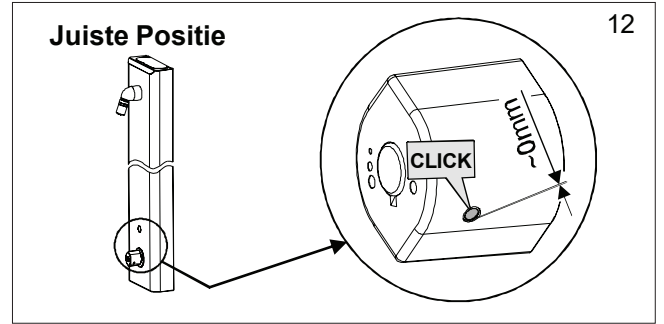
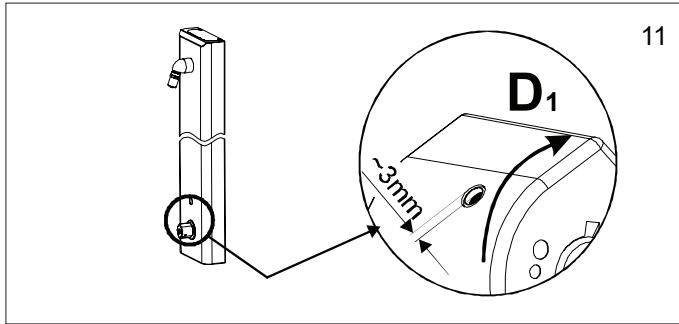
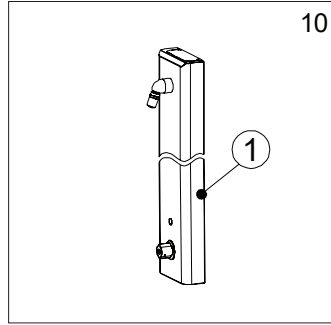
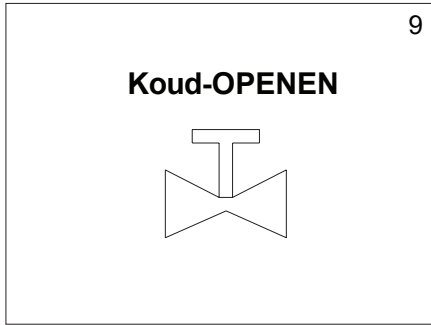
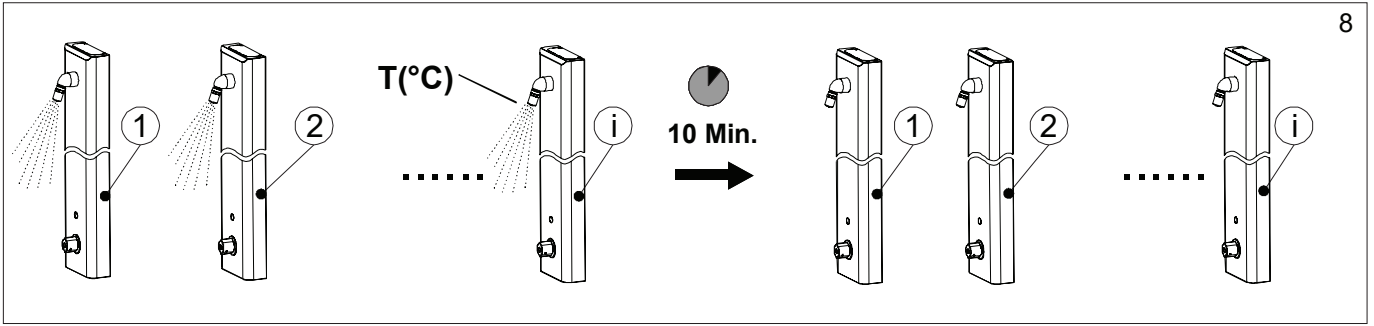

## 9. Storingen oplossen

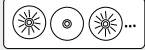
Storing	Oorzaak	Oplossing
Er stroomt geen water	• Afsluiter(s) dicht	Afsluiter(s) openen
	• Batterij leeg	Batterij vervangen
	• Sensor werkt niet	Rada bellen/emailen
LED blinkt 	• Batterij leeg	Batterij vervangen
Er stroomt te weinig water	• Zeefilters verstopt • Perlator verstopt • Afsluiter(s) deels dicht	Zeefilters reinigen Sproeiplaat reinigen Afsluiter(s) openen
Water stroomt continu	• Magneetventiel defect	Afsluiter dicht zetten en Rada Service bellen
Spontaan plotseling startende kraan	• Reflectie door objecten in het detectiebereik	Servicetest starten en storende reflectiebronnen verwijderen

## 10. Belangrijke informatie

**Batteriehouders en CR-P2 6V Batterij** (Bestelnr.: 1336913)

**Netadapter** (Bestelnr.: 1336904) wordt NIET meegeleverd.

**Geen** reinigingsmiddelen gebruiken die alcohol, ammoniak, zuur, zwavel, schuurmiddel of chloor bevatten.

## 11. Onderdelen

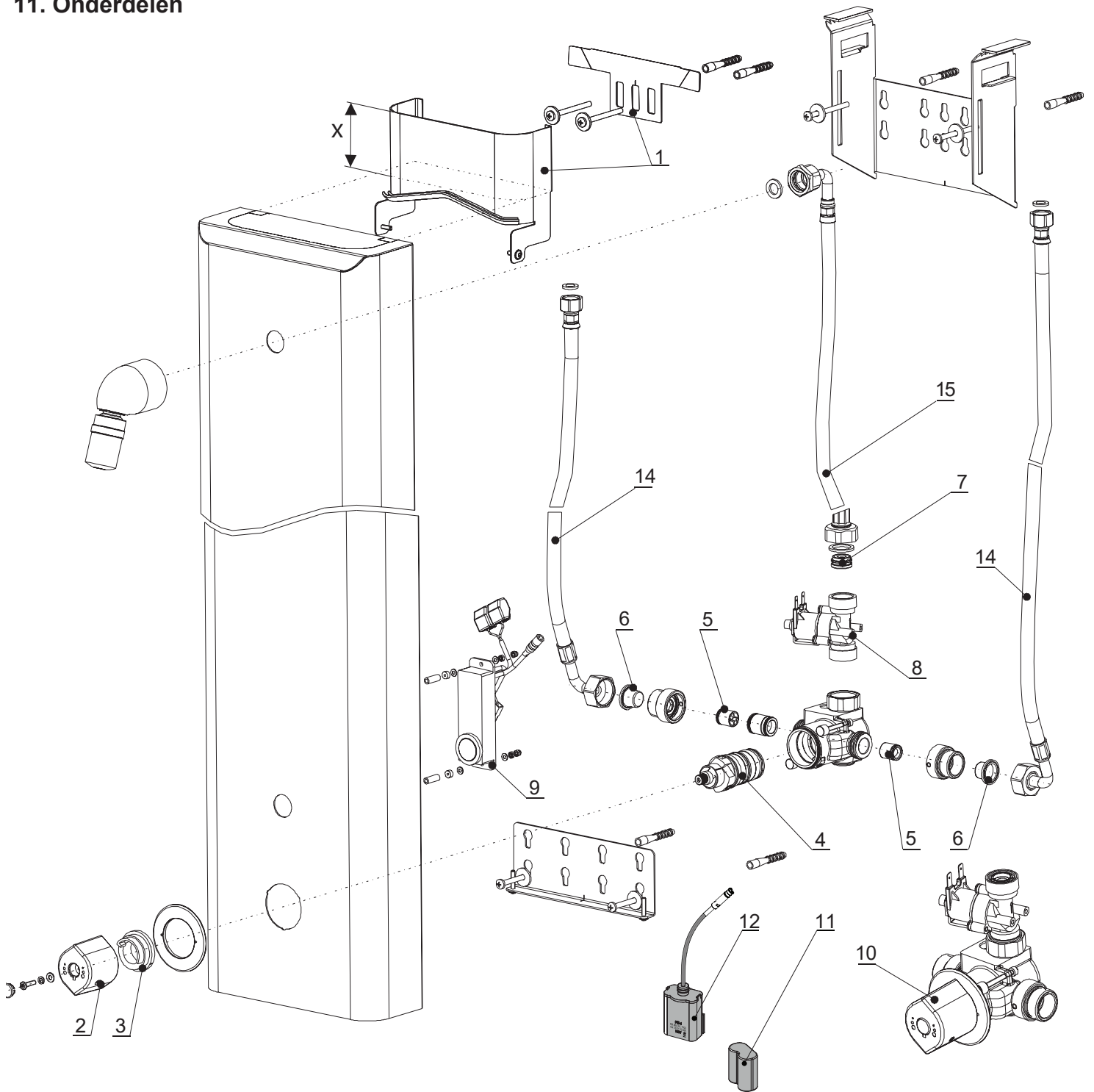

2	1336911	Thermostaatknop
3	2.1930.542	Draaiknop aanslagring
4	2.1930.541	Thermostaatpatroon
5	1518517	Keerlepinsert
6		Zeeffilter
7		Volumestroombegrenzer 12 l/min
8		Magnetventiel
9		Elektronica
10		Thermostaatblok met magneetventiel
11	1336913	Batterij 6V Typ CR P2
12	1336905	Batterijhouder

# KLANTENINFORMATIE

## Kwaliteitsgarantie

Dit product heeft een wettelijke garantie die start op de aankoopdatum. Binnen de garantieperiode zullen materiaalgebreken kosteloos verholpen worden door reparatie of vervanging.

### De garantie geldt onder de navolgende omstandigheden:

- Het product moet geïnstalleerd en onderhouden zijn volgens de algemene installatierichtlijnen en de richtlijnen in deze handleiding.
- Reparatie geschiedt enkel door ons of door ons daartoe aangewezen personen.
- Reparatie onder garantie verlengt de garantieperiode niet. De garantie op vervangen onderdelen eindigt op het einde van de originele garantieperiode
- Voor garantie op douchekoppen en andere consumentenartikelen hebben wij het recht om enkel reserve onderdelen te versturen.

### De garantie geldt niet voor:

- De kosten van servicebezoeken voor fouten en storingen die niet als oorzaak het product hebben (bijvoorbeeld problemen en storingen door incorrect installeren, incorrect gebruik, gebrek aan onderhoud, kalk- en vuilafzettingen, vorstschade en vuil in (dichtzittende) zeeffilters) of waar geen fouten/ gebreken in het product gevonden kunnen worden.
- Problemen ontstaan door waterzijdige of elektrisch problemen.
- De compensatie van het niet kunnen gebruiken van het product of daaraan verwante zaken.
- Storingen en fouten veroorzaakt doordat het product gerepareerd of aangepast is door niet door ons daartoe bevoegde personen.
- Routinematige onderhoud en/of te vervangen onderdelen in het kader van richtlijnen voor routinematig onderhoud.

## Wat te doen bij een storing

Indien het product bij ingebruikname niet goed functioneert, neem dan contact op met uw installateur om te controleren of het product geïnstalleerd en ingeregeld is zoals aangegeven in de handleiding.

Indien dit het probleem niet oplost kunt u contact opnemen met Rada Sanitairtechniek B.V.

Indien de prestaties van het product verminderen, controleer dan aan de hand van deze handleiding of onderhoud nodig is. Neem contact met ons op voor advies.

## Rada Klantenondersteuning

### Service helpdesk

Onze commercieel technische mensen op kantoor kunnen u ondersteunen met advies over storingen, onderdelen, accessoires of een bezoek van onze servicedienst. Zorg dat u productnaam en type, evenals aankoopdatum bij de hand hebt.

### Onderdelen en Accessoires

Wij hebben onderdelen en accessoires voor onze producten op voorraad ter ondersteuning gedurende de levensduur van het product.

### Servicedienst

Wij bieden u de mogelijkheid het onderhoud en reparaties uit te laten voeren door onze eigen Rada servicedienst.

### Service contracten

Periodiek onderhoud van onze producten is essentieel voor blijvend goede prestaties en veiligheid.

Wij bieden u de mogelijkheid het jaarlijks onderhoud aan de Rada producten uit te laten voeren door onze eigen Rada servicedienst.

Neem contact op met:

**Rada Sanitairtechniek BV**  
**Anthonie Fokkerstraat 81**  
**3772 MP Barneveld**

**T. +31 342 41 40 8**

**E. info@rada-nl.c**

**W. ww .radacontrols.com**

Rada is een geregistreerd handelsmerk van Kohler Mira Limited. Wij behouden ons het recht voor om producten te wijzigen zonder kennisgeving vooraf.



FM 14648

